

Network models of three-dimensional electromagnetic fields

I. INTRODUCTION

One of the oldest techniques for electromagnetic field analysis and computation relies on magnetic and/or electric field equivalent circuits. Historically such circuits tended to be simple with few degrees of freedom due to limitations to available computing power and memory; notwithstanding, these methods are still helpful in providing efficient estimates of global parameters and are used for teaching purposes as they are well based physically and avoid complicated mathematical descriptions. They are also used in real time simulations and for analysis of complex structures. Dramatic increases in computer speed and available memory have removed many restrictions and progressively more accurate models are being used based mainly on the finite element (FE) formulations.

The principal advantage of the equivalent networks is that they provide useful physical insight and rely on well known and understood Kirchhoff's and Ohm's laws for electric and magnetic circuits [6, 16, 18]. The solution uses methods from circuit theory which are generally considered by engineers as much simpler than finite element formulations. It is therefore not surprising that researchers have long been searching for analogies between field descriptions and network equivalents.

The authors have for many years taught courses on finite elements and have developed a network description of the FE formulation which allows the method to be explained using the language of circuit theory [7, 8, 9, 11]. This article presents briefly such an approach, discusses the use of potentials and shows various possible descriptions of the elements using nodal, edge, facet and volume formulations. An 8node hexahedron is used to illustrate the implementation of the general ideas.

II. ELECTROMAGNETIC FIELD EQUATIONS

The electromagnetic field may be described using the usual set of equations

$$\text{curl } \mathbf{H} = \mathbf{J}, \quad \text{curl } \mathbf{E} = -\partial \mathbf{B} / \partial t \quad (1a,b)$$

$$\mathbf{H} = \mathbf{v} \mathbf{B}, \quad \mathbf{J} = \sigma \mathbf{E} + \partial(\epsilon \mathbf{E}) / \partial t \quad (2a,b)$$

where the expression for current density refers to two components: conduction (using conductivity σ of material) and displacement current due to time variation of the electric field. For brevity we introduce the notation

$$\mathbf{J} = \gamma \mathbf{E} \quad (3)$$

where $\gamma = \sigma + p\epsilon$ (and $p = \partial/\partial t$) contains both components and may be referred to as 'operational' conductivity.

In wave problems an alternative to (1a) is often used, in which current density is expressed in terms of a time derivative of an electric flux density \mathbf{D} , which yields $\text{rot } \mathbf{H} = \partial \mathbf{D} / \partial t$, while $\mathbf{D} = \epsilon_p \mathbf{E}$, and an 'operational' electric constant $\epsilon_p = p^{-1} \gamma = p^{-1} \sigma + \epsilon$.

From (1b) it follows that $\text{div } \mathbf{B} = 0$, as there may be no 'free' magnetic poles, and from (1a) we can deduce $\text{div } \mathbf{J} = 0$, which expresses the law of conservation of charges in the absence of free electric charge (in other words the continuity of conduction current, or the field equivalent of Kirchhoff's current law). The equations $\text{div } \mathbf{B} = 0$ and $\text{div } \mathbf{J} = 0$, together with (1a) or (1b), are normally used when the magnetic and electric fields are considered separately, for example when seeking field distributions due to imposed current density or solving equations describing current density distributions resulting from time variation of the prescribed flux density.

Electromagnetic fields may be solved using field equations directly (\mathbf{H} , \mathbf{B} , \mathbf{E} or \mathbf{D}) or by introducing potential functions. The potential formulations are considered more general and will be discussed here. There are three main approaches based on potentials: (a) the Ω - T method, where the magnetic field is expressed in terms of a scalar potential Ω , while the electric field is described using an electric vector potential \mathbf{T} ; (b) the A - V formulation, where A is a magnetic vector potential and V an electric scalar potential; and (c) the A - T formulation based on magnetic and electric vector potentials.

Table I. Equations for the different potential formulations

Method	Substitution	Equations
Ω - T	$\mathbf{J} = \text{curl } \mathbf{T}$ $\mathbf{H} - \mathbf{T} = \text{grad } \Omega$	$\text{div} [\mu(\text{grad } \Omega + \mathbf{T})] = 0$ $\text{curl}(\gamma^{-1} \text{curl } \mathbf{T}) = -\frac{\partial}{\partial t} [\mu(\text{grad } \Omega + \mathbf{T})]$
A - V	$\mathbf{B} = \text{curl } \mathbf{A}$ $\mathbf{E} + \frac{\partial \mathbf{A}}{\partial t} = \text{grad } V$	$\text{curl}(\mathbf{v} \text{curl } \mathbf{A}) = \gamma \text{grad } V - \gamma \frac{\partial \mathbf{A}}{\partial t}$ $\text{div} [\gamma(\text{grad } V - \frac{\partial \mathbf{A}}{\partial t})] = 0$
A - T	$\mathbf{J} = \text{curl } \mathbf{T}$ $\mathbf{B} = \text{curl } \mathbf{A}$	$\text{curl}(\mathbf{v} \text{curl } \mathbf{A}) = \text{curl } \mathbf{T}$ $\text{curl}(\gamma^{-1} \text{curl } \mathbf{T}) = -\frac{\partial}{\partial t} (\text{curl } \mathbf{A})$
T A	$\mathbf{T} = \mathbf{H}$ $\mathbf{E} = -\frac{\partial \mathbf{A}}{\partial t}$	$\text{curl}(\gamma^{-1} \text{curl } \mathbf{T}) = -\frac{\partial}{\partial t} (\mu \mathbf{T})$ $\text{curl}(\mathbf{v} \text{curl } \mathbf{A}) = -\gamma \frac{\partial \mathbf{A}}{\partial t}$

Table I gathers field expressions relevant to the various formulations. The bottom row refers to the case when the Ω - T and A - V formulations are reduced to simpler forms through the assumption of $\text{grad } \Omega = 0$ and $\text{grad } V = 0$, respectively. As a result the two equations become decoupled and may be solved independently. Moreover, the solution becomes unique with appropriate choice of the gauge condition. Gauging of the solution is an important issue and appropriate conditions are often added to the governing equations. However, some recent publications on numerical methods suggest that gauging

may not always be necessary [2, 7, 17]. By using numerical techniques such as relaxation methods or ICCG, one of the possible solutions is found satisfying the equations for potentials. Finding one of the solutions may be faster than searching for the only one satisfying the gauge conditions [2, 17].

The following discussion concentrates on the ungauged solutions. Using the language of the circuit theory, the finite element method is derived for all three potential formulations.

III. FINITE ELEMENT INTERPOLATION FUNCTIONS

A final element may be considered as nodal, edge, facet or volume [3, 9, 12]. In the nodal formulation the distribution of a scalar quantity inside an element is expressed in terms of the values at nodes (e.g. vertices). An edge element describes a vector quantity in that element through the values of integrals of this quantity along the element edges – these integrals are known as edge values. In a facet element the function describing a distribution of a vector quantity inside is associated with the surface integrals of that quantity on the element facets – the integrals are known as facet values. Finally, a volume element may be defined if a distribution of a scalar quantity is expressed in terms of known volume integrals of this quantity – the integrals are called the volume values. As a consequence of the multiplicity of integration, a volume element may be referred to as an element of the third order, a facet element as second order, an edge element as first order and a nodal element as zero order. For the element of the i th order we can write

$$y_i = \sum_{j=1}^{n_i} w_{i,j} y_{i,j} \quad (i = 0, 1, 2, 3) \quad (4)$$

where $y_{i,j}$ is the j th nodal value for $i=0$, edge value for $i=1$, facet value for $i=2$ and volume value for $i=3$; $w_{i,j}$ is the j th interpolating function of the element of the i th order; and n_i is the number of values of the field quantity y_i (n_i equals the number of nodes for $i=0$, the number of edges for $i=1$, the number of facets for $i=2$ and the number of volumes for $i=3$; typical elements have one volume, hence $n_3=1$). The interpolating functions for elements of third and zero order are scalar.

Equation (4) may be written in a matrix form

$$y_i = \mathbf{w}_i \mathbf{Y}_i \quad (i = 0, 1, 2, 3) \quad (5)$$

Here \mathbf{w}_i is a matrix of interpolating functions of the element of i th order, and \mathbf{Y}_i a vector of associated values, e.g. a vector of nodal ($i=0$), edge ($i=1$), facet ($i=2$) or volume ($i=3$) values. The values and interpolating functions of the edge and facet elements, that is elements of the first and second order, are vectors; accordingly they are further designated using bold letters.

As the field quantities describing magnetic fields, as well as their sources, are themselves vectors, it is often beneficial to use interpolating functions which are also vectors and thus make the best use of edge and facet elements.

IV. FINITE ELEMENT GRAPHS

In electromagnetic field systems the functions $w_{1,j}$ of the edge element are used to describe: (a) a gradient of the electric, V , or magnetic, O , scalar potential, (b) electric or magnetic field strength, or (c) electric, T , or magnetic, A , vector potentials. The functions $w_{2,j}$ of the facet element, on the other hand, are related to the current density \mathbf{J} or the magnetic flux density \mathbf{B} . The edge values of the relevant field intensities represent voltages, whereas the edge values of the vector potentials T and A are linked with the loop currents and fluxes around the edge, respectively. The facet value of \mathbf{J} is a current, while the facet value of \mathbf{B} is a flux through the facet [9].

Let a vector quantity y_1 be expressed in terms of a gradient of a scalar y_0 , i.e. $y_1 = \text{grad}y_0$. Hence the edge value $y_{1,j}$ for the j th edge, with the start at P_p and the end at P_q , may be written as

$$y_{1,j} = \int_{P_p}^{P_q} \mathbf{y}_1 d\mathbf{l} = y_0(P_q) - y_0(P_p) \quad (6)$$

This relationship shows that the edge value of the gradient equals the potential difference between the edge ends. This may be written in matrix form for all edges of a finite element mesh as

$$\mathbf{Y}_1 = \mathbf{k}_w \mathbf{Y}_0 \quad (7)$$

where \mathbf{Y}_1 is the vector of the edge values of $\text{grad}y_0$, \mathbf{Y}_0 a vector of the nodal values of y_0 , and \mathbf{k}_w a transposed nodal matrix of a graph whose branches coincide with the edges of the discretising mesh (Fig. 1). Equation (7) is a network representation of the substitution $y_1 = \text{grad}y_0$. For electromagnetic systems \mathbf{Y}_1 becomes a vector of branch voltages and \mathbf{Y}_0 a vector of nodal values of a scalar potential. For the remainder of this article, the graphs and networks with branches coinciding with the finite element mesh will be referred to as *edge networks* (EN) [9, 11].

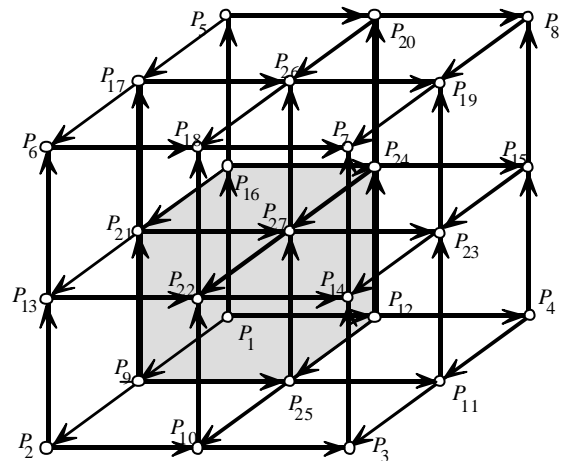

Fig. 1. Edge graph of 8 hexahedrons

In the electromagnetic field analysis it is common practice to express the current and flux densities in terms of a circulation of a vector potential. The vector potentials represent a vector quantity y_1 associated with an edge element, while densities \mathbf{B} and \mathbf{J} correspond to a vector quantity y_2 related to a facet element. Using the aforementioned substitution we obtain $y_2 = \text{curly}y_1$. After a

facet value $y_{2,j}$ has been determined following the above definition of y_2 and by applying the Stoke's theorem we obtain

$$y_{2,j} = \sum_q \pm y_{1,q} \quad (8)$$

Here the summation refers to the edge values of all edges of the j th facet. The sign in front of the q th edge value $y_{1,q}$ depends on the direction of the q th edge. For all mesh facets we can write

$$Y_2 = k_s Y_1 \quad (9)$$

where Y_2 is a vector of the facet values, and k_s is a transposed loop matrix of a graph whose nodes are positioned in the centre of element volumes and the branches connecting the nodes cut the facets as shown in Fig. 2. This type of graph and associated networks have been named *facet networks* (FN) [9, 11]. The matrix k_s refers to loops around the edges and is also the loop matrix of the edge graph where edges are linked with relevant facets. Equation (9) is a network equivalent of the substitution $y_2 = \text{curl} y_1$ and expresses branch values using loop values.

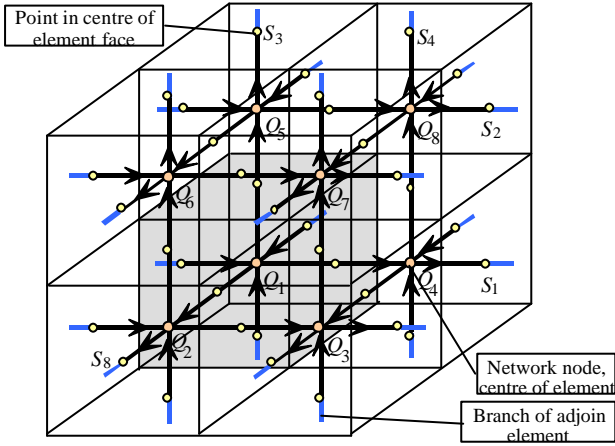

Fig. 2. Facet graph of 8 hexahedrons

Table II. Network representations of differential operators

Differential operations	Network equivalents of the differential operations	
	Edge graph	Facet graph
div y	$k_w^T Y_1$	$k_v Y_2$
curl y	$k_s Y_1, k_s^T Y_2$	$k_s Y_1, k_s^T Y_2$
grad y	$k_w Y_0$	$k_v^T Y_3$
curl grad $y=0$	$k_s k_w = 0$	$k_s^T k_v^T = 0$
div curl $y=0$	$k_w^T k_s^T = 0$	$k_v k_s = 0$

Referring now to the volume value $y_{3,j}$ of a quantity y_3 , considering that it is a divergence of a vector y_2 , and applying Gauss theorem, leads to the following expression

$$y_{3,j} = \sum_p \pm y_{2,p} \quad (10)$$

where the summation involves the facet values $y_{2,p}$ of all facets of the j th volume. For all elements of the

discretising mesh we can write

$$Y_3 = k_v Y_2 \quad (11)$$

where Y_3 is a vector of volume values, and k_v a matrix of cuts of the edge graph, with cuts associated with facets. These matrices are network representations of the differential operators as explained in Table II.

V. BRANCH EQUATIONS FOR EDGE ELEMENT MODELS

The vector functions which are associated with an edge element are: the electric and magnetic field intensity, the potential gradient and the vector potentials. The edge values of these functions for the edge $N_{i,j}$ with the beginning at P_i and the end at P_j , are assembled in Table III.

Table III. Edge values of the field vectors for an edge $N_{i,j}$ with the beginning at P_i and an end at P_j

Quantity	Edge value	Description of the edge value
grad V	$V_j - V_i$	Electric potential difference between nodes
grad Ω	$\Omega_j - \Omega_i$	Magnetic potential difference between nodes
H	$u_{HN_{i,j}}$	Magnetic potential associated with branch permeance
E	$u_{EN_{i,j}}$	Electric potential associated with operational branch admittance
A	$\phi_{oN_{i,j}}$	Loop flux around the edge
T	$i_{oN_{i,j}}$	Loop current around the edge

Using the relationships from Table I, $H - T = \text{grad} \Omega$ and $E + \partial A / \partial t = \text{grad} V$, it is possible to establish correlations between the edge values of Table III. Integrating both sides along the edge $N_{i,j}$ leads to the following expressions

$$u_{HN_{i,j}} - i_{oN_{i,j}} = \Omega_j - \Omega_i \quad (12a)$$

$$u_{EN_{i,j}} + d\phi_{oN_{i,j}} / dt = V_j - V_i \quad (12b)$$

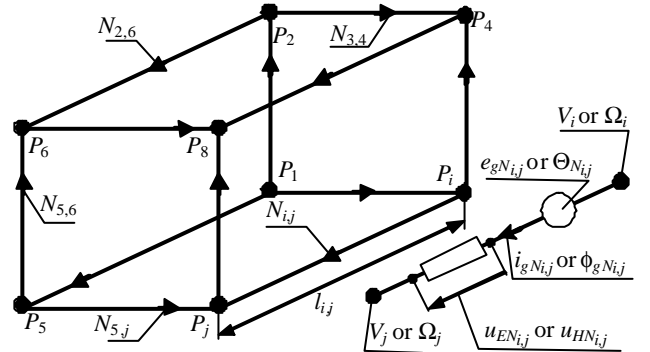

Fig. 3. An edge model of an 8-node, 12-edge element.

The implications of expressions (12a) and (12b) are as follows. The potential difference between nodes of the branch $N_{i,j}$ of the edge graph (e.g. that of Fig. 3) is a sum of the branch electromotive force (*emf*) $e_{gN_{i,j}}$ or magnetomotive force (*mmf*) $\Theta_{N_{i,j}}$ and the voltage drop

$u_{EN_{i,j}}$ or $u_{HN_{i,j}}$ across the branch elements (the branch $N_{i,j}$ is associated with the edge $N_{i,j}$). The branch *emf* is expressed in terms of the time derivative of the flux around the edge, $e_{gN_{i,j}} = -d\phi_{oN_{i,j}}/dt$. The branch *mmf* corresponds to the loop current i_{oij} , $\Theta_{N_{i,j}} = i_{oN_{i,j}}$.

The current $i_{gN_{i,j}}$ in the branch $N_{i,j}$ of the edge model of a single element containing an electric field may be obtained using the following expression

$$i_{gN_{i,j}} = \iiint_{V_e} \mathbf{w}_{1,N_{i,j}} \mathbf{J} \, dv \quad (13)$$

where V_e is the element volume. Equation (3) should be used, while the \mathbf{E} vector may be described in terms of the interpolating functions of the edge element, yielding

$$\mathbf{J} = \gamma \mathbf{E} = \gamma \mathbf{w}_1 \mathbf{u}_E \quad (14)$$

where \mathbf{w}_1 is a matrix of the edge element functions – see (5), and \mathbf{u}_E is a vector of edge values of the electric field strength \mathbf{E} . Substituting (14) into (13) gives

$$i_{gN_{i,j}} = \sum_{N_{p,q}=1}^{m_1} (G_{N_{i,j},N_{p,q}} + p C_{N_{i,j},N_{p,q}}) u_{EN_{p,q}} \quad (15)$$

where

$$G_{N_{i,j},N_{p,q}} = \iiint_{V_e} \mathbf{w}_{1,N_{i,j}} \sigma \mathbf{w}_{1,N_{p,q}} \, dv \quad (16a)$$

$$C_{N_{i,j},N_{p,q}} = \iiint_{V_e} \mathbf{w}_{1,N_{i,j}} \epsilon \mathbf{w}_{1,N_{p,q}} \, dv \quad (16b)$$

It can be deduced that when formulating an edge model of an element subjected to an electric field, mutual conductances and capacitances will emerge. The voltage across the admittance of the branch $N_{p,q}$ will create conduction and displacement currents in the branch $N_{i,j}$.

Following a similar derivation as when establishing (15), it is possible to find an expression for the magnetic flux $\phi_{gN_{i,j}}$ associated with branch $N_{i,j}$ of an edge model of an element in the presence of magnetic field:

$$\phi_{gN_{i,j}} = \sum_{N_{p,q}=1}^{m_1} \Lambda_{N_{i,j},N_{p,q}} u_{Hp,q} \quad (17)$$

where

$$\Lambda_{N_{i,j},N_{p,q}} = \iiint_{V_e} \mathbf{w}_{1,N_{i,j}} \mu \mathbf{w}_{1,N_{p,q}} \, dv \quad (18)$$

Here, expression (18) describes permeances. It can be seen that, in the edge model of an element with a magnetic field, one encounters mutual permeances. The magnetic potential across the permeance of the branch $N_{p,q}$ creates a flux in the branch $N_{i,j}$. In the model of a rectangular parallelepiped, the mutual conductances and capacitances between branches associated with perpendicular edges are equal to zero.

It has been shown by the authors that for a mesh which is sufficiently fine the integrals (16) and (18) may be approximated using the values of the integrand in the element vertices [7, 8] by using the following relationship

$$\iiint_{V_e} f(x, y, z) \, dv = V_e \frac{1}{n_0} \sum_{i=1}^{n_0} f(P_i) \quad (19)$$

A simplified model is thus established for a parallelepiped, where

$$G_{N_{i,j},N_{p,q}} = 0, \quad C_{N_{i,j},N_{p,q}} = 0, \quad \Lambda_{N_{i,j},N_{p,q}} = 0 \quad \text{for } N_{i,j} \neq N_{p,q} \quad (20a,b,c)$$

$$G_{N_{i,j},N_{i,j}} = \sigma \frac{V_e}{4l_{i,j}^2}, \quad C_{N_{i,j},N_{i,j}} = \epsilon \frac{V_e}{4l_{i,j}^2},$$

$$\Lambda_{N_{i,j},N_{i,j}} = \mu \frac{V_e}{4l_{i,j}^2} \quad (21a,b,c)$$

where $l_{i,j}$ is the length of the edge $N_{i,j}$ – see Fig. 3. Similar expressions may be obtained by applying classical methods, e.g. the integral formulation, or using rubes and slices [14]. In the edge model of a parallelepiped, if (19) has been applied, there will be no couplings between branches, that is no mutual permeances, conductances or capacitances.

The edge model of an element with a magnetic field, as described by (17) and (18), will be referred to as the permeance model or *edge magnetic* (EM). Following similar logic, the edge model of an element with an electric field, expressed by (15) and (16), will be known as the conductance-capacitance or *edge electric* (EE).

VI. BRANCH EQUATIONS FOR FACET ELEMENT MODELS

The vector quantities which are associated with a facet element are: (a) magnetic flux density \mathbf{B} , and (b) current density \mathbf{J} . The facet values of these quantities, related to the i th facet, are: (a) magnetic flux ϕ_{sj} passing through the facet, and (b) current i_{sj} flowing through the facet. These values correspond to the branch flux and current in the branch Q_1S_j of the facet model of the element, as shown in Fig. 4. By making the substitutions $\mathbf{B} = \text{curl} \mathbf{A}$ and $\mathbf{J} = \text{curl} \mathbf{T}$, and applying (9), these values may be expressed in terms of edge vector potentials, that is using loop currents and fluxes

$$\phi_{sj} = \sum_{N_{p,q}} k_{sj,N_{p,q}} \phi_{oN_{p,q}}, \quad i_{sj} = \sum_{N_{p,q}} k_{sj,N_{p,q}} i_{oN_{p,q}} \quad (22a,b)$$

where $k_{sj,N_{p,q}}$ is an element of the j th row and $N_{p,q}$ th column of the matrix \mathbf{k}_s for a graph of a single element.

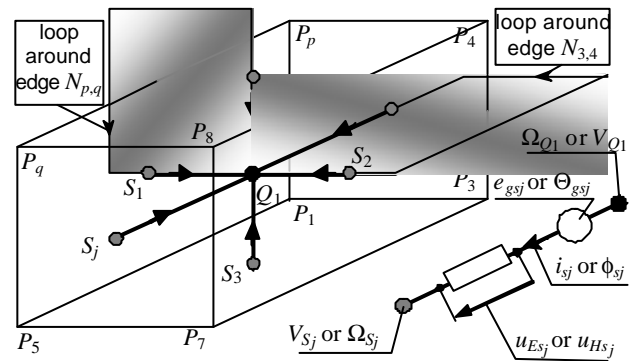

Fig. 4. A facet model of an 8-node, 12-edge element.

An expression for the magnetic potential between nodes for the branch Q_1S_j of the facet model may be derived using the following relationship

$$\iiint_{V_e} \mathbf{w}_{2,j} \text{grad} \Omega \, dv = \iiint_{V_e} \mathbf{w}_{2,j} \mathbf{H} \, dv - \iiint_{V_e} \mathbf{w}_{2,j} \mathbf{T} \, dv \quad (23)$$

The above expression is a result of the multiplication of the substitution $\mathbf{H} - \mathbf{T} = \text{grad} \Omega$ by the j th interpolating function $\mathbf{w}_{2,j}$ of a facet element and subsequent integration. By applying the identity

$$\mathbf{w}_{2,j} \text{grad} \Omega = \text{div}(\mathbf{w}_{2,j} \Omega) - \Omega \text{div} \mathbf{w}_{2,j} \quad (24)$$

and taking into account that $\text{div} \mathbf{w}_{2,j} = \mathbf{w}_3 \mathbf{k}_{V_j}$, where \mathbf{k}_{V_j} is the j th column of the matrix \mathbf{k}_V , then for an element of a single volume, in which $\mathbf{w}_3 = \mathbf{w}_{3,1} = V_e^{-1}$, we find

$$\iiint_{V_e} \mathbf{w}_{2,j} \text{grad} \Omega \, dv = S_j^{-1} \iint_{S_j} \Omega \, dS - V_e^{-1} \iiint_{V_e} \Omega \, dv = \Omega_{S_j} - \Omega_{Q_1} \quad (25)$$

where Ω_{S_j} is an average value of the potential of the j th facet associated with the node S_j , and Ω_{Q_1} is an average value of the potential within the volume of the element associated with the node Q_1 of the edge graph. Thus the left hand side of (23) represents the voltage between nodes. When considering the right hand side of (23) the following relationships are helpful

$$\mathbf{H} = \nu \mathbf{B} = \nu \mathbf{w}_2 \mathbf{f}_s, \quad \mathbf{T} = \mathbf{w}_1 \mathbf{i}_o \quad (26a,b)$$

Here \mathbf{f}_s denotes the vector of fluxes passing through facets, thus branch fluxes, and \mathbf{i}_o the vector of loop currents i_{oij} . Substituting (26) into (23) via (24) yields

$$\Omega_{S_j} - \Omega_{Q_1} = \sum_{i=1}^{n_2} R_{\mu Q_{1,i}, Q_{1,j}} \phi_{si} - \Theta_{gsj} \quad (27)$$

where

$$R_{\mu Q_{1,i}, Q_{1,j}} = \iiint_{V_e} \mathbf{w}_{2,i} \nu \mathbf{w}_{2,j} \, dv \quad (28a)$$

$$\Theta_{gsj} = \sum_{N_{p,q}=1}^{m_1} K_{j,N_{p,q}} i_{op,q} \quad (28b)$$

and

$$K_{j,N_{p,q}} = \iiint_{V_e} \mathbf{w}_{2,j} \mathbf{w}_{1,N_{p,q}} \, dv \quad (29)$$

In the branch equation (27) mutual reluctances $R_{\mu Q_{1,i}, Q_{1,j}}$ may be recognised. The magnetic flux in the i th branch, that is in the branch between nodes Q_1 and S_i (Fig. 4), creates a flux in the j th branch between nodes Q_1 and S_j . The branch *mmf* Θ_{gsj} may be expressed in terms of loop (mesh) currents in the loops ‘embracing’ element edges.

In a similar way an expression may be derived for a magnetic voltage between nodes in the branch Q_1S_j of the facet model of an element with an electric field:

$$V_{S_j} - V_{Q_1} = \sum_{j=1}^{n_s} Z_{Q_{1,i}, Q_{1,j}} i_{si} - e_{gsj} \quad (30)$$

where

$$Z_{Q_{1,i}, Q_{1,j}} = \iiint_{V_e} \mathbf{w}_{2,i} \gamma^{-1} \mathbf{w}_{2,j} \, dV \quad (31a)$$

$$e_{gsj} = - \sum_{N_{p,q}=1}^{m_1} K_{j,N_{p,q}} (\rho \phi_{op,q}) \quad (31b)$$

In the branch equation (30) there are mutual impedances of the capacitive type. A current in the i th branch triggers a voltage in the j th branch.

From the relationship (31a) one can deduce expressions for branch resistances for models without displacement currents, as well as branch ‘elastances’ [9], if such currents are present and conduction currents are negligible. The facet model of an element with an electric field has been named the impedance or *facet electric* (FE) model. The facet model of an element with a magnetic field is known as the reluctance or *facet magnetic* (FM) model.

The branch parameters of facet models may be established using (19). For example, for a parallelepiped, the following expressions are found

$$R_{\mu Q_{1,i}, Q_{1,j}} = 0, \quad Z_{Q_{1,i}, Q_{1,j}} = 0 \quad \text{for } i \neq j \quad (32a,b)$$

$$R_{\mu Q_{1,j}, Q_{1,j}} = \nu \frac{V_e}{2S_j^2}, \quad Z_{Q_{1,j}, Q_{1,j}} = (\sigma + p\epsilon)^{-1} \frac{V_e}{2S_j^2} \quad (33a,b)$$

where S_j is the surface area of the i th facet. As a result, a simplified model of the parallelepiped element is achieved, without couplings between branches, whose parameters are the same as those found using classical approaches, for example a method described in [14].

VII. MODELS OF CONNECTED ELEMENTS

Edge models

Network models of a meshed region are obtained by connecting element models. In the case of an edge model the branches associated with common element edges are connected in parallel. As a result a multi-branch permeance model (EM) is established for a magnetic field or multi-branch conductance-capacitance model (EE) for an electric field.

The vectors \mathbf{i}_g and \mathbf{f}_g of branch currents in EE and branch fluxes in EM may be written in the matrix form

$$\mathbf{i}_g = (\mathbf{G} + p\mathbf{C}) \mathbf{u}_E, \quad \mathbf{f}_g = \mathbf{L} \mathbf{u}_H \quad (34a,b)$$

where \mathbf{G} , \mathbf{C} and \mathbf{L} are the matrices of branch conductances, capacitances and permeances, respectively; and \mathbf{u}_E , \mathbf{u}_H refer to the vectors of potential differences across elements of the branches of EE or EM. Taking account of (12) allows for these vectors to be written as

$$\mathbf{u}_E = \mathbf{k}_w \mathbf{V} + \mathbf{e}_g, \quad \mathbf{u}_H = \mathbf{k}_w \mathbf{W} + \mathbf{Q}_g \quad (35a,b)$$

where \mathbf{V} and \mathbf{W} are vectors of node potentials; \mathbf{e}_g and \mathbf{Q}_g are vectors of branch *emfs* and *mmfs*; and \mathbf{k}_w is a transposed nodal matrix for the edge graph of the system of connected elements.

In models created using 6-facet elements the branches contain four capacitances and conductances or permeances connected in parallel, such as the branch P_iP_j in Fig. 5.

From the above relationships the nodal equations for the permeance network may be established

$$\mathbf{k}_w^T \mathbf{L} \mathbf{k}_w \mathbf{W} + \mathbf{k}_w^T \mathbf{L} \mathbf{Q}_g = \mathbf{0} \quad (36)$$

and similarly for the conductance-capacitance network

$$\mathbf{k}_w^T (\mathbf{G} + \mathbf{pC}) \mathbf{k}_w \mathbf{V} + \mathbf{k}_w^T (\mathbf{G} + \mathbf{pC}) \mathbf{e}_g = \mathbf{0} \quad (37)$$

The derived equations correspond to the description of the nodal element method (NEM) using scalar potentials.

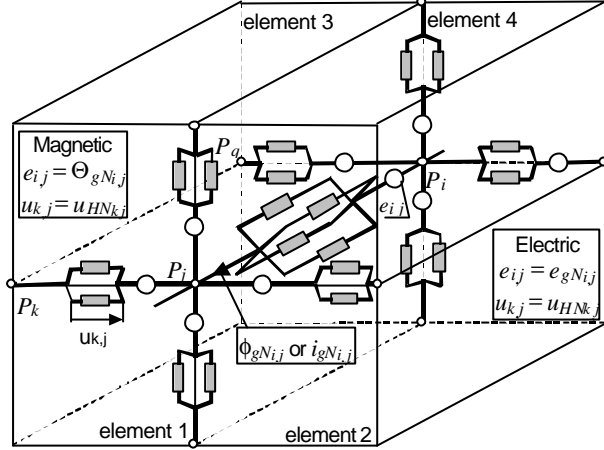

Fig. 5. Part of an edge model of four elements with details of a branch associated with the edge $P_i P_j$

Facet models

When assembling elements for the facet electric (FE) or facet magnetic (FM) model of a meshed region, the branches associated with common facets are connected in series. As a result, a network is established whose nodes are points Q_i associated with centres of the volumes, as shown in Fig. 6. Voltage equations for a branch containing nodes Q_i may be written as

$$\mathbf{u}_{Hs} = \mathbf{R}_\mu \mathbf{f}_s, \quad \mathbf{u}_{Es} = \mathbf{Z} \mathbf{i}_s \quad (38a,b)$$

where \mathbf{R}_μ and \mathbf{Z} are the matrices of branch reluctances and branch operational impedances; whereas \mathbf{f}_s and \mathbf{i}_s are vectors of branch fluxes and currents. The vectors \mathbf{u}_{Hs} and \mathbf{u}_{Es} may be written in the following form

$$\mathbf{u}_{Hs} = \mathbf{k}_V^T \mathbf{W}_o + \mathbf{Q}_{gs}, \quad \mathbf{u}_{Es} = \mathbf{k}_V^T \mathbf{V}_o + \mathbf{e}_{gs} \quad (39a,b)$$

where \mathbf{W}_o and \mathbf{V}_o are vectors of the nodal potentials associated with centres of elements; \mathbf{Q}_{gs} and \mathbf{e}_{gs} are vectors of branch *mmfs* and *emfs*; finally \mathbf{k}_V is the matrix mentioned previously of cuts for the network of connected edge element models.

The vectors \mathbf{f}_s and \mathbf{i}_s of branch fluxes and currents are edge vector values of flux and current density, respectively. They may be expressed in terms of edge values of vector potentials, thus in terms of loop fluxes \mathbf{f}_o and loop currents \mathbf{i}_o in the loops around the edge of a set of connected elements. We may write

$$\mathbf{f}_s = \mathbf{k}_s \mathbf{f}_o, \quad \mathbf{i}_s = \mathbf{k}_s \mathbf{i}_o \quad (40a,b)$$

where \mathbf{k}_s is the aforementioned transposed loop matrix of the facet graph of the connected elements. Fig. 6 depicts part of the facet model of four elements showing a loop 'embracing' the edge $P_i P_j$.

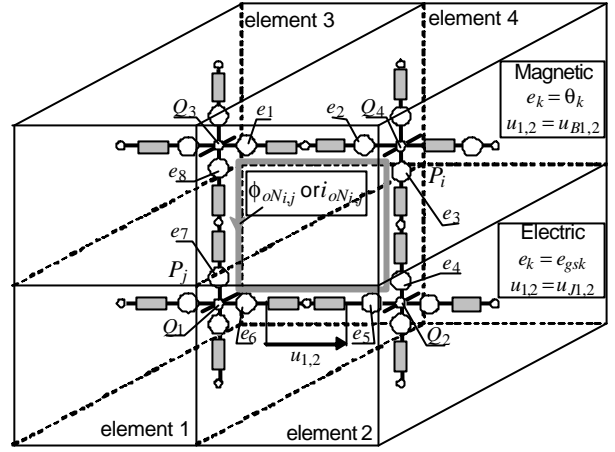

Fig. 6. Part of a facet model of four elements with a loop around the edge $P_i P_j$

Loop equations for a reluctance model (SM) of a system with a magnetic field may be established from equations (38), (39) and (40) as

$$\mathbf{k}_s^T \mathbf{R}_\mu \mathbf{k}_s \mathbf{f}_o = \mathbf{k}_s^T \mathbf{Q}_{gs} \quad (41)$$

Similarity loop equations for the resistance-elasticity model (SE) with an electric field may be written as

$$\mathbf{k}_s^T \mathbf{Z} \mathbf{k}_s \mathbf{i}_o = \mathbf{k}_s^T \mathbf{e}_{gs} \quad (42)$$

The loop equations (41) and (42) correspond to edge element formulation (EEM) if vector potentials are used. They may be derived by minimizing the functional with respect to edge values of potentials. Although the approach is known as the edge element method, the branch reluctance and impedance matrices are in fact set up using interpolating functions of the facet element, as shown by equations (28a) and (31a). The functions of the edge element, on the other hand, are helpful when creating the coefficient matrix for the nodal element method, for which the network equivalent is the edge network. In expressions for branch conductances and capacitances as well as for branch permeances of the edge network an absence of classical shape functions of nodal elements may be noticed, as shown by (16) and (18). Notwithstanding, expressions for nodal permeance matrix $\mathbf{k}_w^T \mathbf{L} \mathbf{k}_w$ and admittance matrix $\mathbf{k}_w^T (\mathbf{G} + \mathbf{pC}) \mathbf{k}_w$ are the same as in classical finite element formulation using nodal element. There are, however, differences between the two descriptions when it comes to sources.

VIII. BRANCH AND LOOP SOURCES

In the models considered the branch *mmfs* and *emfs* are described in terms of loop quantities. The branch sources in the facet network (FN) result from loop values in the edge network (EN), whereas branch sources in FN from loop values in EN. Branch *mmfs* Q_b in EN correspond to loop currents \mathbf{i}_o in FN, e.g. the *mmf* in the branch $P_i P_j$ of the magnetic network of Fig. 5 is equal to the current in a loop of the electric network that surrounds the edge $P_i P_j$ (Fig. 6). Branch *emfs* e_b in EN are found by time differentiation of loop fluxes \mathbf{f}_o in FN, hence sources in (36) and (37) may be written as

$$\mathbf{Q}_g = \mathbf{i}_o, \quad \mathbf{e}_g = -d\mathbf{f}_o/dt. \quad (43a,b)$$

Branch *mmfs* q in FM are represented by loop currents i_{oe} in the loops of the edge network, e.g. the branch *mmf* in the branch Q_1Q_3 of the magnetic FN of Fig. 6 corresponds to the loop current in the loop $P_iP_jP_qP_k$ of the electric edge network of Fig. 5. The time derivative of the flux in the loop $P_iP_jP_qP_k$ of the EM equals (with negative sign) the *emf* in the branch Q_1Q_3 of the FE. Sources in (41) and (42) may therefore be written as

$$Q_{gs} = i_{oe}, \quad e_{gs} = -df_{oe}/dt. \quad (44a,b)$$

where the subscript *oe* denotes vectors of loop currents and fluxes in the edge networks.

When loop analysis is applied to a network it is not necessary to determine the branch sources, the knowledge of loop sources will suffice. For example, when dealing with (41) and (42), it is not essential to establish vectors Q_{gs} and e_{gs} of the branch sources, we can focus on deriving loop sources Q_m and e_m

$$Q_m = k_s^T Q_{gs}, \quad e_m = k_s^T e_{gs} \quad (45a,b).$$

The loop *mmf* corresponds to the current passing through a loop of a magnetic network, hence the loop *mmfs* Q_m in the facet network are equivalent to branch currents i_g in the edge network, e.g. the *mmf* of the loop shown in Fig 6 (a loop around the edge P_iP_j) is equal to the current in the branch P_iP_j of the electric network of Fig. 5. The loop *emfs*, on the other hand, may be found by time differentiating of branch fluxes in the magnetic network passing through loops of the electric network, e.g. loop *emfs* e_m in the electric facet network are derived from fluxes associated with branches of the magnetic edge network as $e_m = -df_g/dt$. Thus when solving (41) and (42) it may be convenient to take into account that

$$k_s^T Q_{gs} = Q_m = i_g, \quad k_e^T e_{gs} = e_m = -df_g/dt \quad (46a,b)$$

In order to establish branch fluxes f_g and branch currents i_g , as well as loop fluxes f_{oe} and loop currents i_{oe} associated with edge networks, it is not necessary to solve the equations for these networks. Instead, quantities associated with edge networks may be derived from by appropriate transposition of the results for the facet network. The required entries of the transposing matrix K may be found as a product of interpolating functions of the facet and edge elements – as shown by (29). Substitution for K results in the following

$$f_{oe} = K f_o, \quad i_{oe} = K i_o, \quad (47a,b)$$

$$f_g = K^T f_s, \quad i_g = K^T i_s. \quad (48a,b)$$

Moreover, the matrix K may be used to derive currents i_o and i_s , as well as fluxes f_o and f_s , associated with facet networks, from currents i_{oe} and i_g , and also fluxes f_{oe} and f_g , associated with edge networks

$$f_o = K^T f_{oe}, \quad i_o = K^T i_{oe}. \quad (49a,b)$$

$$f_s = K f_g, \quad i_s = K i_g. \quad (50a,b)$$

The abovementioned relationships are explained in Fig. 7, where 6-facet elements are considered for which all non-zero entries in K are equal to 1/8.

The loop *mmfs* in FM may therefore be established

from: (a) branch currents i_g in EE; (b) loop currents i_o in FE; or (c) branch currents i_s in FE. Equally, to find loop *emfs* in FE we may use: (a) branch fluxes f_g in EM; (b) loop fluxes f_o in FM; or (c) branch fluxes f_s in FM. Due to the bigger variety of descriptions of sources, the facet models are more universal than edge models; this also explains – using the language of circuit theory – why the vector potential formulations are more universal.

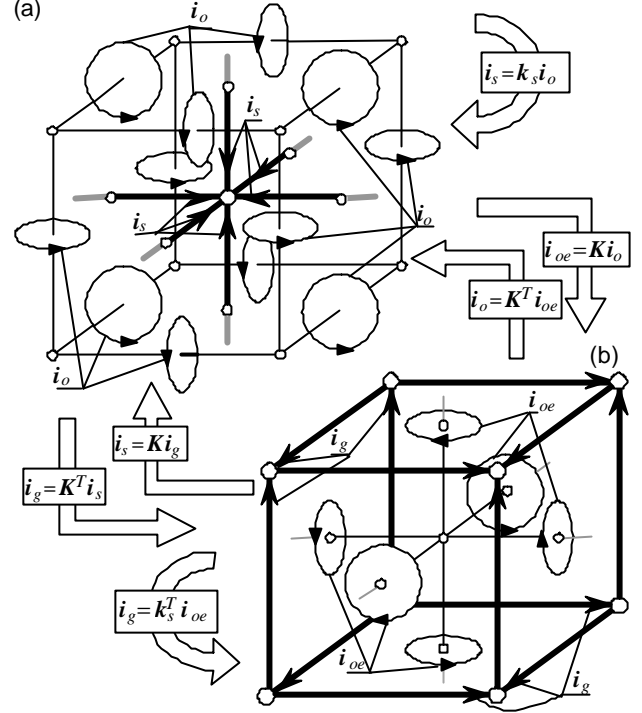

Fig. 7. Transformations of loop and branch currents in networks (a) facet graph, (b) edge graph

IX. COUPLED NETWORK MODELS

The finite element formulations using potentials correspond to equations of magnetic and electric networks coupled via sources.

A-T method

Formulations based on the vector potentials A and T are related to loop equations arising from magnetic and electric facet networks (FM-FE).

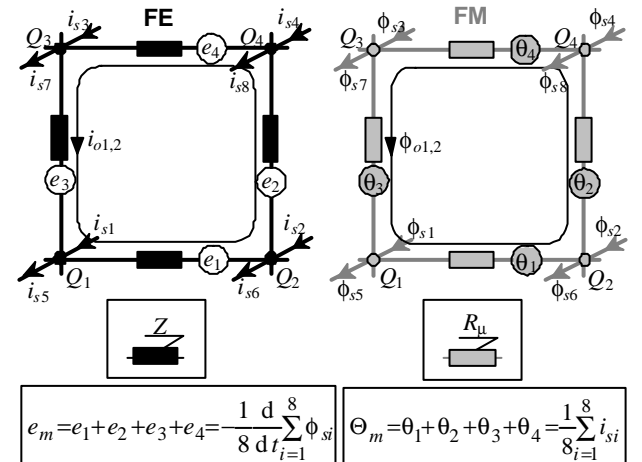

Fig. 8. Portion of an FM-FE model

Loop *mmfs* in a magnetic network are derived from branch currents in the electric network (Fig. 8). Similarly,

from the branch fluxes of the magnetic network we can establish the flux passing through a loop in the electric network. Time derivatives of these fluxes correspond (with negative sign) to loop *emfs*. The method is particularly suitable for analysis of systems containing thin conductors. In such systems, from the loop equations of the facet electric model the loop equations for circuits containing windings may be established. After taking account of the presence of voltage sources, a system of equations is accomplished containing voltage equations for the windings and FEM equations describing loop fluxes distribution in the magnetic facet network [10].

A-V method

The equations arising from the A-V method, which uses magnetic vector potential and electric scalar potential, contain loop equations of the facet magnetic network and nodal equations of the edge electric network [8, 11]. Coupling exists between the facet magnetic network and edge electric network (FM-EE). Loop *mmfs* in the magnetic network are derived from branch currents of the electric network, while branch *emfs* in the electric network are found by differentiating with respect to time of the loop fluxes in the magnetic network (Fig. 9).

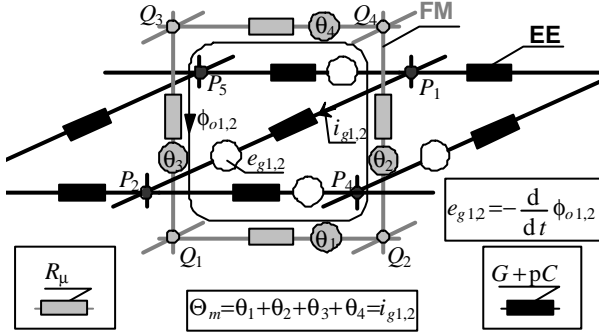

Fig. 9. Portion of an FM-EE model

Ω-T method

The method uses a magnetic scalar potential Ω and an electric vector potential T . The resulting equations consist of nodal expressions for the edge magnetic network and loop equations for the facet electric network. The model therefore contains coupled magnetic edge and electric facet networks (EM-FE). The loop *emfs* are obtained from branch fluxes of the magnetic network, while branch *mmfs* in the edge network from loop currents of the facet network, as shown in Fig. 10.

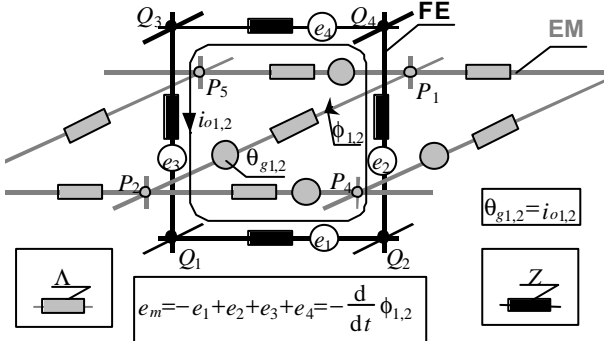

Fig. 10. Portion of a permeance-impedance network

This approach has rarely been used so far. Most commercial codes use two potentials: global and reduced,

while the flow of conduction current is treated as a circuit problem. Moreover, the equivalence between loop currents and the edge values of electric vector potential T is normally overlooked. By taking account of this equivalence, the circuit-field models using the potential O may be treated as a special case of the Ω - T formulation.

O-V method

The authors are not aware of publications addressing specifically field analysis using only scalar potentials Ω and V . From the discussion above it follows that the network representation of the equations based on the O-V formulation would involve nodal equations of two edge networks, magnetic and electric. Unfortunately, it is not possible to develop branch *mmfs* in EE from branch currents in EE, nor branch *emfs* in EE from branch fluxes in EE. A separate derivation is thus required to establish loop currents and fluxes from branch currents and fluxes, since branch sources in edge networks are defined via loop quantities. The loop values are network equivalents of vector potentials. It may be concluded therefore that the application of the Ω - V formulation would necessitate an additional task of determining the distribution of vector potentials from the knowledge of the scalar potential distribution. For this reason the Ω - V method is considered of little real practical interest and the relevant equations are not elaborated. The equations for the other models are summarised in Table IV.

Table IV. Equations from the coupled network models

Model	Equations
EM-FE Ω - T	$k_w^T L k_w W + k_w^T L Q_g = 0, \quad Q_g = i_o$ $k_s^T Z k_s i_o = e_m, \quad e_m = -p L (k_w W + Q_g)$
FM-EE A-V	$k_s^T R_\mu k_s f_o = Q_m, \quad Q_m = (G+pC)(k_w V + e_g)$ $k_w^T (G+pC) k_w V + k_w^T (G+pC) e_g = 0, \quad e_g = -p f_o$
SM-SE A-T	$k_s^T R_\mu k_s f_o = Q_m, \quad Q_m = k_s^T K i_o$ $k_s^T Z k_s i_o = e_m, \quad e_m = -k_s^T N p f_o$
FE, T FM, A	$k_s^T Z k_s i_o = e_m, \quad e_m = -p L i_o \quad (i_o = u_H)$ $k_s^T R_\mu k_s f_o = Q_m, \quad Q_m = (G+pC) p f_o \quad (-p f_o = u_E)$

In the bottom row of Table IV, the ‘decoupled’ equations are presented describing loop currents and fluxes in facet models. The relationship for loop fluxes f_o is obtained from equations of the FM-EE model, after imposing the condition $k_w V = 0$. The appropriateness of this condition may be considered by examining the structure of the graph matrices of the facet and edge networks and the properties of the vector Q_m on the right hand side of loop equations for magnetic network in the FM-EE model. This vector is a factor in the system of nodal equations of the network EE. The nodal equations of EE may be written as $k_w^T Q_m = 0$. The transposed matrix k_w is the nodal matrix of the edge network. At the same time, the matrix k_s appearing in the equations of the FM-EE model, is the loop matrix of this network (loops

are associated with element facets). Consequently, $\mathbf{k}_w^T \mathbf{k}_s^T = \mathbf{0}$, and thus multiplying both sides of the equation $\mathbf{k}_s^T \mathbf{R}_\mu \mathbf{k}_s \mathbf{f}_o = \mathbf{Q}_m$ by a transposed matrix \mathbf{k}_w leads to $\mathbf{k}_w^T \mathbf{Q}_m = \mathbf{0}$. Thus the solution satisfying loop equations for FM for the loops around the edges, also satisfies nodal equations for EE, even for $\mathbf{k}_w \mathbf{V} = \mathbf{0}$. If in the system considered there are no enforced voltages, then when computing the field distribution we may assume that $\mathbf{V} = \mathbf{0}$. As a result the task of solving equations of the FM-EE model reduces to a solution of a system of equations describing the loop fluxes \mathbf{f}_o , i.e. the system included in the bottom row of Table IV. Hence the electric field distribution may be established by differentiation in time of these fluxes, since, as $\mathbf{V} = \mathbf{0}$, then from (35b) and (43b) it follows that $\mathbf{u}_E = -\mathbf{p} \mathbf{f}_o$. In a similar way, by substituting $\mathbf{W} = \mathbf{0}$ in the equations of the Ω - T method, equations describing currents \mathbf{i}_o may be derived and are included in the bottom row of Table IV. The relationships in that row may be considered as equations of the edge element method for field formulations.

The loop equations for facet networks presented in Table IV for coupled models are ill-posed (underspecified), as the number of independent loops around edges is larger than the number of available independent equations. The loop reluctance and impedance matrices are therefore singular. In early publications about the implementations of EEM the solution algorithms were preceded by procedures to form additional equations to arrive at a well posed system. Several methods were put forward, for example a method utilising the tree of the graph constructed from element edges [13, 15]. In the FM-EE and EM-FE models a well posed system will be accomplished by adding the conditions $\mathbf{V} = \mathbf{0}$ and $\mathbf{W} = \mathbf{0}$. Unfortunately, the known iterative procedures for solving large system of equations are in this case known to be converging rather slowly [2, 17].

Converting EEM equations into a well posed system is not a necessary requirement to obtain a solution. Using an appropriate iterative method, such as ICCG or block relaxation, it is possible to solve these equations, or – to be more precise – find one of the equations satisfying EEM. The iterative process of seeking one of the solutions is converging faster than the process of finding one unique solution of a well posed system [2, 17]. The authors have conducted some tests using the FM-EE model. The comparison concerned the convergence of the well posed system, obtained by adding the condition $\mathbf{V} = \mathbf{0}$, and the convergence of an iterative process applied to an underspecified system of equations established using FM and EE models. Despite the fact that incorporating the condition $\mathbf{V} = \mathbf{0}$ reduces the number of equations, as there is no need to consider EE, the solution times are longer than for the underspecified system. The number of iterations for solving equations for FM under the condition $\mathbf{V} = \mathbf{0}$ was sometimes even two orders of magnitude higher than for the combined FM and EE set.

Using the presented network descriptions it is possible to form models ‘tuned in’ to a particular structure, material properties and imposed conditions. As an example, a system is considered containing thin

conductors. First, a task of computing magnetic field distribution due to known currents in windings is undertaken, assuming negligible displacement currents. To solve this problem it is convenient to use a permeance model, whose nodal equations correspond to equations NEM using a formulation based on the scalar potential O . In the system under investigation containing thin filamentary conductors, the branch *mmfs* may be determined from loop currents in the loops of the winding arrangement, after dividing the winding loops into loops around the edges, as described in detail in [10]. Fig. 11 shows an example of a double-turn loop with current and a portion of the permeance network (EM), representing the region within the boundary of the loop. The nodes of the presented portion of the network lie on the plane $z=0$. The given values of the branch *mmfs* have been determined by considering the number of cuts of the element edges with the loop surface [10]. From the distribution of these *mmfs* it follows that, in the portion of the network shown, the non-zero values of *mmfs* are only in loops O_1 and O_4 , through which the current carrying conductors pass (Fig. 11). It will also be noted that, thanks to expressing field sources using branch *mmfs*, it is feasible to employ only one global scalar potential [10]. In the actual algorithm of the nodal method, the branch *mmfs* are converted into nodal ‘injections’ of flux (nodal sources). The vector \mathbf{F} of these injections is described by the term $\mathbf{k}_w^T \mathbf{L} \mathbf{Q}_g$ in (36).

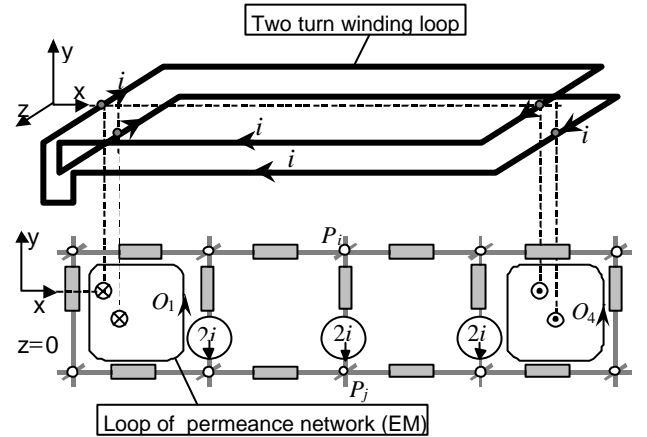

Fig. 11. A portion of the permeance coil model of a region with a two-turn coil

It has already been noticed that, in order to describe current distributions in thin conductors supplied from voltage sources, it is most convenient to use the vector potential T . If displacement currents are absent or negligible, then the corresponding to this formulation loop equations of the impedance network may be greatly simplified. By using methods presented in [10], from loop equations of FE, the equations for currents \mathbf{i}_{wo} in the loops of the thin conductors forming the winding may be determined. These equations may be written in a matrix form

$$\mathbf{R}_o \mathbf{i}_{wo} = \mathbf{k}_m^T \mathbf{e}_m + \mathbf{u}_{zo} \quad (51)$$

where \mathbf{R}_o is the loop resistance matrix of the system of thin conductors; and \mathbf{u}_{zo} is the vector of imposed loop supplying voltages. The matrix \mathbf{k}_m describes the

distribution of the winding in the edge element domain [10]. The product of the transposed matrix k_m and the vector e_m (from Table IV) corresponds to the vector of $emfs$ set up by the flux coupled with the winding loops. The matrix equation (51) may be solved together with the equations for model EM or model FM. When defining the sources it should be remembered that $i_o = k_m i_{uo}$.

The additional ‘external’ circuit currents i_{uo} may be considered as the edge values of a vector potential T_0 , used otherwise in description of multiply connected conductors [4], including analysis of eddy currents in solid conductors with ‘holes’ [1, 5]. After applying EEM to the T formulation, equations representing loop equations of facet network are established. These equations refer to loops with eddy currents around the element edge. Although the number of these loops exceeds the number of independent loops, for a system which is not singly connected it is impossible to set up the system of fundamental loops. It is therefore necessary, for loops around the edges, to supplement the loop equations with equations for additional loops surrounding the ‘holes’. The currents of these loops provide edge values for the potential T_0 . The authors are of the opinion that the above explanation, expressed using the language of circuit theory, of the need for the introduction of the additional potential T_0 , is more convincing than the purely ‘field oriented’ arguments available in the literature.

The network representation of FEM equations is also applicable to the analysis of wave propagation. Fig. 12 shows a network model of a plane electromagnetic wave. The model consists of two coupled networks: facet magnetic and edge electric. Even a short voltage impulse applied to a capacitance in an arbitrary k th branch will create currents even in very distant branches.

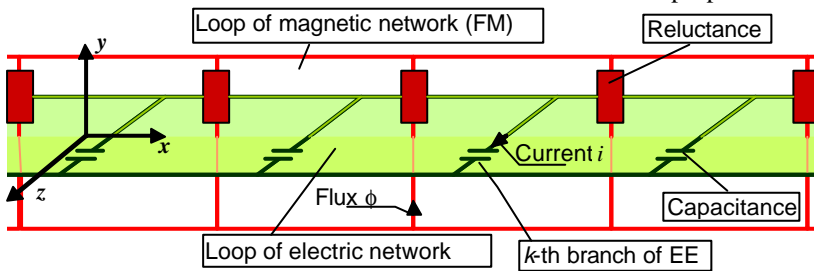

Fig.12. Network model of a region with a plane wave,
 $E=1_z E_z(x)$, $H=1_y H_y(x)$

X. CONCLUSIONS

The article has introduced a notation for the finite element formulation where the description of field quantities is in terms of interpolating functions of an element considered as edge or facet element. In the formulation using functions of an edge element, the edge values of a gradient of a scalar potential are expressed in terms of nodal values. This approach may therefore be called a nodal element method, for brevity, even if the field quantities are described using the functions of the edge element. On the other hand, in the formulation based on the functions of the facet element, the facet values are expressed using edge values of a vector potential, hence it is justifiable to call the method an edge element method.

Equations of the nodal element method for formulations employing scalar potentials correspond to nodal equations of edge networks: electric conductance-capacitance and magnetic permeance. Nodes of the edge network coincide with the element nodes. Equations of the edge element method, on the other hand, for formulations using vector potentials correspond to loop equations of facet networks: magnetic reluctance and electric resistance-elasticity. The nodes of the facet network lie in the volume centres of the elements, while loops ‘embrace’ the element edges. The field analysis methods based on scalar potentials represent therefore nodal methods of analysis of electric and magnetic circuits, whereas the field methods employing vector potentials represent the loop approach in circuits.

A particular characteristic of the circuits which serve as analogies to magnetic or electric field systems is the ‘loop’ character of the sources. From the distribution of the current density a loop mmf may be specified, whereas the time variation of the flux density determines the loop emf . For this reason, in the algorithms for the scalar potential method, the routines for solution of FEM are preceded by a procedure forming the sources associated with nodes. In the cases discussed in this article the sources are expressed in terms of edge values of vector potentials, that is in terms of loop currents and fluxes. From these values the branch $emfs$ and $mmfs$ are derived, which – in the process of setting up nodal expressions – are then converted into current and flux injections. As a result, in models of even very non-homogenous regions the sum of the sources associated with nodes is equal to zero and there is no need to use two potentials, global and reduced.

As mentioned already, it is possible to tune the models to cater for particular specific conditions or properties. For example, resistance models can be created of systems containing windings with rod conductors (such as in cage induction motors) where skin effects need to be considered. It is also possible to create models for systems containing displacement currents.

The presented approach is fundamentally different to the classical way of deriving the finite element equations. Probably the most popular derivation relies on a variational principle where the conditions are sought through differentiating the function with respect to nodal, edge or facet values. It is important to emphasise, however, that the final equations are identical to those presented in this article. One of the aims of this presentation is to demonstrate that the finite element formulation may be derived entirely from circuit theory without the introduction of the concept of energy functional.

The presented analogies between FEM equations and circuit equations may also be useful to update and enhance the well known and long-in-use network methods of analysis of magnetic circuits, including the permeance networks [6, 16] and reluctance networks [18]. To improve the accuracy of representation of regions of high energy density, the parameters of these models should be established using the expressions presented in this article.

Details of the solution of large systems of equations resulting from the various networks discussed have not been addressed here. Nevertheless, it was noted that the iterative procedures of solving ill-posed (underspecified) loop equations for facet elements are very efficient. Careful analysis has shown that the loop method does not require the dependent loops to be eliminated.

REFERENCES

- [1] Biro O., Preis K., Renhart W., Richter K.R. and Vrisk G., "Performance of different vector potential formulations in solving multiply connected 3 D eddy current problems." *IEEE Trans. on Magnetics*. Vol. 26, No. 2, pp.438-441, 1990.
- [2] Biro O., Preis K. and Richter K., "On the use of magnetic vector potential in the nodal and edge element analysis of 3d magnetostatic problems," *IEEE Trans. on Magnetics*, Vol. 32, No. 3, pp. 651-654, 1996.
- [3] Bossavit A., *Computational Electromagnetism, Variational Formulations, Complementarity, Edge Elements*, San Diego Academic Press, 1998.
- [4] Bouissou S. and Piriou F., "Numerical simulation of a power transformer using finite element method coupled to circuit equation," *IEEE Trans. on Magnetics*, Vol. 30, No.5, pp. 3224-3227, 1994.
- [5] Bui V. P, Le Floch Y., Meunier G. and Coulomb J.L., "A new three-dimensional (3-D) Scalar Finite Element Method to Compute T_0 ," *IEEE Trans. on Magnetics*, Vol. 42, No. 4, pp. 1035-1038, 2006.
- [6] Davidson A. and Balchin M. J., "Three dimensional eddy currents calculation using a network method," *IEEE Trans. on Magnetics*, Vol. 19, No. 6, pp. 2325-2328, 1983.
- [7] Demenko A., Nowak L. and Szelag W., "Reluctance network formed by means of edge element method," *IEEE Trans. on Magnetics*, Vol. 34, No. 5, pp. 2485-2488, 1998.
- [8] Demenko A., "Three-dimensional eddy current calculation using reluctance-conductance net work formed by means of FE method," *IEEE Trans. on Magnetics*. Vol. 36, No. 4, pp.741-745, 2000.
- [9] Demenko A. and Sykulski J. K., "Network equivalents of nodal and edge elements in electromagnetics," *IEEE Trans. on Magnetics*, Vol. 38, No. 2, pp. 1305-1308, 2002.
- [10] Demenko A., "Representation of windings in the 3D finite element description of electromagnetic converters," *IEE Proceedings Science, Measurement and Technology*, Vol. 149, No. 5, pp. 186-189, 2002.
- [11] Demenko A. and Sykulski J. K., "Magneto-electric network models in electromagnetism," *COMPEL*, Vol., No, pp. , 2006.
- [12] Dular P., Hody J., Nicolet A., Genon A. and Legros W., "Mixed finite elements associated with a collection of tetrahedra, hexahedra and prisms," *IEEE Trans. on Magnetics*, Vol. 30, No. 5, pp. 2980-2983, 1994.
- [13] Goliás N.A. and Tsiboukis T.D., "Magnetostatics with edge elements: a numerical investigation in the choice of the tree," *IEEE Trans. on Magnetics*, Vol. 30, No. 5, pp. 2877-2880, 1994.
- [14] Hammond P. and Sykulski J. K., *Engineering Electromagnetism: Physical Processes and Computation*, Oxford University Press, 1994.
- [15] Manges J. B. and Cendes Z. J., "A generalised tree-cotree gauge for magnetic field computation," *IEEE Trans. on Magnetics*, Vol. 31, No. 3, pp. 1142-1147, 1995.
- [16] Ostrovic V., *Dynamics of saturated electric machines*, Springer-Verlag, Berlin, 1898.
- [17] Ren Z., "Influence of R.H.S. an the convergence behaviour of the curl-curl equation," *IEEE Trans. on Magnetics*, Vol. 32, No. 3, pp. 655-658, 1996.
- [18] Sykulski J. K., Stoll J., Sikora R., Pawluk K., Turowski J. and Zakrzewski K., *Computational Magnetics*, London, Chapman & Hall, 1995.

Andrzej Demenko andrzej.demenko@put.poznan.pl

Jan K. Sykulski jks@soton.ac.uk