

Dariusz Spalek
Silesian University of Technology
Electrical Engineering Faculty
ul. Akademicka 10, 44-100 Gliwice, Poland
e-mail: Dariusz.Spalek@polsl.pl

Spherical induction motor with anisotropic rotor

- analytical solutions for electromagnetic field distribution, electromagnetic torque and power losses

Abstract. The work deals with the problem of electromagnetic field analysis for spherical electromechanical converters taking into account its magnetic anisotropy in analytical way. The electromagnetic field is evaluated analytically using the separation method for the magnetic vector potential. The electromagnetic torque and power losses are calculated analytically for an exemplary spherical induction motor.

Key words: Spherical motor, magnetically anisotropic rotor, analytical solution.

1. Motivation

The analytical solution gives better insight into the influence of electromagnetic circuit parameters on the operation than the numerical solution. However, the analytical solution (that is given by one or more closed formulas) usually requires simplification, of the real converter geometry. The fewer the number of the simplifying assumptions the more general solution is obtained. One of the most commonly used analytical methods is the separation of variables [2], [6], [7], [11], [13]. The separation method proposed in the paper leads to the analytical solution for the spherically symmetric field problem considering magnetic anisotropy. The aim of this contribution is to present an analytical solution for a spherical motor with magnetically anisotropic conductive rotor, which could be treated as a benchmark for numerical analyses. Let us consider an induction motor which rotor is spherical – Fig.1

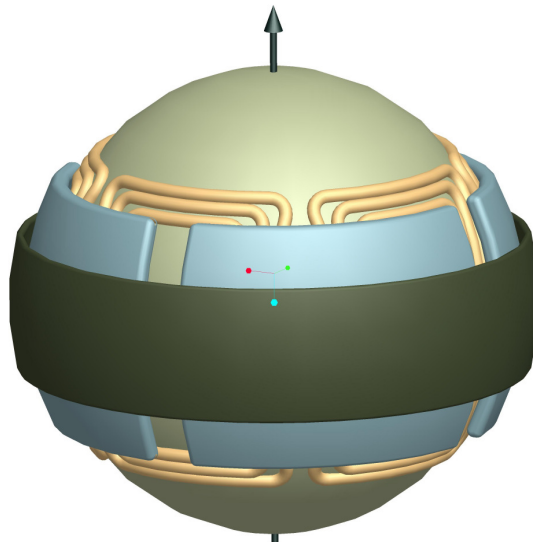

Fig.1. Spherical rotor - view

The most appropriate this problem is the spherical co-ordinate system shown in Fig.2

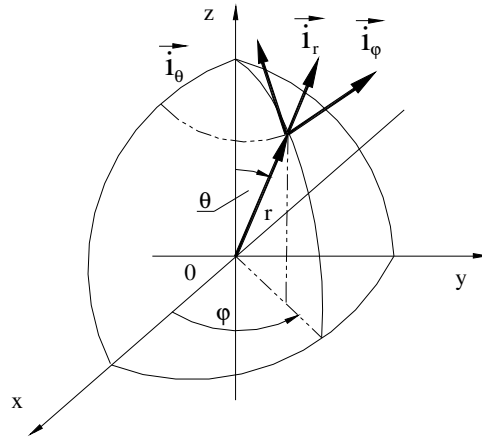

Fig.2. Spherical co-ordinate system

The stator circuits are supplied with currents which flow in the longitudinal direction – Fig.3

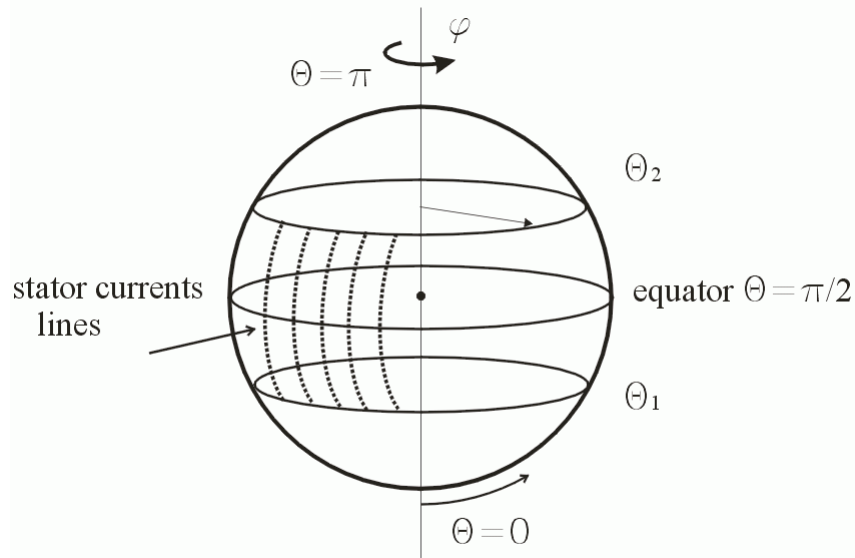

Fig.3. Stator currents lines

The stator currents constitute the magnetomotive force $\Theta_s(t, \varphi, \theta)$ (stator mmf). The magnetomotive force of the stator can be written in complex polyharmonic form as follows

$$\Theta_s(t, \varphi, \theta) = \sum_h (\Theta_{sh}(\theta) \exp(i\omega_h t \mp iph\varphi + \text{const}_h)), \quad (1)$$

where Θ_{sh} denotes the magnitude of the h^{th} harmonic, ω_h is angular speed, p is number of pair pole, φ longitude, θ colatitude. The stator mmf is exerted by the stator currents placed on the inner surface of the stator at $r = R+g$ (R – rotor outer surface radius, g denotes air-gap width).

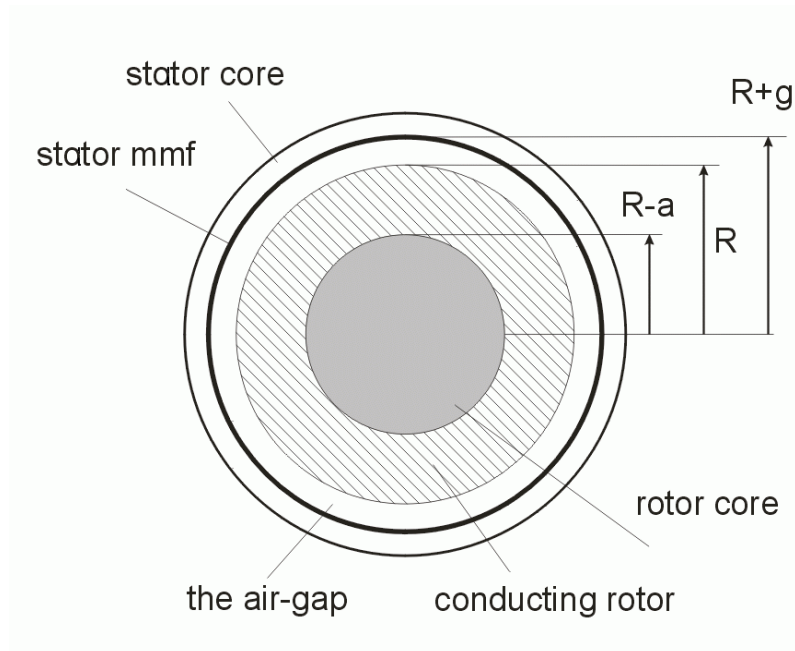

Fig.4. Spherical induction motor - dimensions

The rotor is built with an iron core (whose reluctivity is zero $\nu_{Fe} \rightarrow 0$) and of a conductive layer – see Fig.4. The conductive layer is magnetically anisotropic as given in Eqn (7).

Basing on these assumptions and neglecting displacement currents (due to low field frequency) the magnetic field distribution, electromagnetic torque, stored magnetic energy, eddy current power losses can be calculated analytically.

3. Governing equations and analytical solutions

The magnetic flux density can be calculated in terms of a magnetic vector potential as

$$\vec{B} = \text{curl}(\vec{A}). \quad (2)$$

Eqn (2) leads to the following relation in a spherical co-ordinate system

$$\vec{B} = \frac{\vec{i}_r}{r \sin \theta} \left\{ \frac{\partial A_\theta}{\partial \phi} - \frac{\partial (A_\phi \sin \theta)}{\partial \theta} \right\} - \frac{\vec{i}_\phi}{r} \left\{ \frac{\partial (r A_\theta)}{\partial r} - \frac{\partial A_r}{\partial \theta} \right\} + \frac{\vec{i}_\theta}{r \sin \theta} \left\{ \frac{\partial}{\partial r} r A_\phi \sin \theta - \frac{\partial A_r}{\partial \phi} \right\}. \quad (3)$$

where $\vec{i}_r, \vec{i}_\phi, \vec{i}_\theta$ denote the unit vectors and satisfy the relation $\vec{i}_r \times \vec{i}_\phi = \vec{i}_\theta$.

For an induction motor with spherical rotor [2], [9], [14] the magnetic field is directed so as to enable turning a round a fixed axis (for some solutions the axis can rotate or change its direction). Often, a unidirectional (longitudinal) magnetomotive force (mmf) induces the magnetic field. In this case, the magnetic vector potential in a spherical coordinate system can be given in the form of

$$\vec{A} = \vec{A}_\theta = A_\theta \vec{i}_\theta = A \vec{i}_\theta. \quad (4)$$

According to (4), the above assumption leads to the magnetic flux density in the form

$$\vec{B} = \frac{\vec{l}_r}{r \sin \theta} \left\{ \frac{\partial A_\theta}{\partial \varphi} \right\} - \frac{\vec{l}_\varphi}{r} \left\{ \frac{\partial (r A_\theta)}{\partial r} \right\}, \quad \vec{B}_\theta = 0. \quad (5)$$

Amper's law

$$\text{curl}(\vec{H}) = \vec{j} \quad (6)$$

and the constitutive relation for an anisotropic magnetic medium

$$\begin{bmatrix} H_r \\ H_\varphi \\ H_\theta \end{bmatrix} = \mathbf{v} \begin{bmatrix} B_r \\ B_\varphi \\ 0 \end{bmatrix} = \begin{bmatrix} v_{rr} & v_{r\varphi} & 0 \\ v_{\varphi r} & v_{\varphi\varphi} & 0 \\ 0 & 0 & v_{\theta\theta} \end{bmatrix} \cdot \begin{bmatrix} B_r \\ B_\varphi \\ 0 \end{bmatrix} = \begin{bmatrix} v_{rr} B_r + v_{r\varphi} B_\varphi \\ v_{\varphi r} B_r + v_{\varphi\varphi} B_\varphi \\ 0 \end{bmatrix}, \quad (7)$$

lead to the following equation

$$-\frac{\vec{l}_r}{r \sin \theta} \left\{ \frac{\partial H_\varphi \sin \theta}{\partial \theta} \right\} + \frac{\vec{l}_\varphi}{r} \left\{ \frac{\partial H_r}{\partial \theta} \right\} + \frac{\vec{l}_\theta}{r \sin \theta} \left\{ \frac{\partial}{\partial r} r H_\varphi \sin \theta - \frac{\partial H_r}{\partial \varphi} \right\} = \vec{j}. \quad (8)$$

Due to the assumption that currents flow only in θ -direction, the θ -component of current density (8) is as follows

$$\frac{1}{r \sin \theta} \left\{ \frac{\partial}{\partial r} r H_\varphi \sin \theta - \frac{\partial H_r}{\partial \varphi} \right\} = j_\theta = \gamma E_\theta = -\gamma \dot{A}_\theta, \quad (9)$$

where γ stands for the electric conductivity of rotor layer.

Taking (7) and (9) into account it can be written

$$\frac{1}{r} \frac{\partial}{\partial r} r \left(\frac{v_{\varphi r}}{r \sin \theta} \left\{ \frac{\partial A_\theta}{\partial \varphi} \right\} - \frac{v_{\varphi\varphi}}{r} \left\{ \frac{\partial r A_\theta}{\partial r} \right\} \right) - \frac{1}{r \sin \theta} \frac{\partial}{\partial \varphi} \left(\frac{v_{rr}}{r \sin \theta} \left\{ \frac{\partial A_\theta}{\partial \varphi} \right\} - \frac{v_{r\varphi}}{r} \left\{ \frac{\partial r A_\theta}{\partial r} \right\} \right) = j_\theta. \quad (10)$$

Now, a non-standard separation variable is proposed in the form given below

$$A = A_\theta = R(r, \theta) F(\varphi) = R \cdot F. \quad (11)$$

The separation variable method applied in other way are shows in Table 1. The four plausible variants of separation variables have been considered, but only the fourth one is acceptable.

Table 1. Separation of variable methods

	separation method variant	mathematical form	description
1	$r - \varphi - \theta$	$A = A_\theta = R(r)\Theta(\theta)\Phi(\varphi)$	does not lead to solution
2	$(r, \varphi) - \theta$	$A = A_\theta = R(r, \varphi)F(\theta)$	does not lead to solution
3	$r - (\varphi, \theta)$	$A = A_\theta = R(r)F(\varphi, \theta)$	lead to solution, but it is unacceptable physically
4	$(r, \theta) - \varphi$	$A = A_\theta = R(r, \theta)F(\varphi)$	lead t to solution

Using complex notation the time derivative is replaced by its multiplication by $i\omega$ (i is the imaginary unit, ω is the angular pulsation). Thus (10) takes the following form:

$$\frac{v_{\varphi r}}{rR F \sin \theta} \frac{\partial^2 rR}{\partial r \partial \varphi} - \frac{v_{\varphi \varphi}}{rR} \frac{\partial^2 rR}{\partial r^2} - \frac{v_{rr}}{r^2 F \sin^2 \theta} \frac{\partial^2 F}{\partial \varphi^2} + \frac{v_{r\varphi}}{r^2 R F \sin \theta} \frac{\partial^2 rR}{\partial \varphi \partial r} = \frac{i\omega\gamma}{RF}. \quad (12)$$

for $\theta \in (0, \pi)$, and subsequently

$$\frac{v_{\varphi \varphi}}{rR} \frac{\partial^2 rR}{\partial r^2} + \frac{v_{rr}}{r^2 F \sin^2 \theta} \frac{\partial^2 F}{\partial \varphi^2} - \left(\frac{v_{\varphi r}}{rR} \frac{\partial R}{\partial r} + \frac{v_{r\varphi}}{r^2 R} \frac{\partial rR}{\partial r} \right) \frac{1}{F \sin \theta} \frac{\partial F}{\partial \varphi} = i\omega\gamma. \quad (13)$$

For the function $F(\varphi)$ it is assumed that the separation constant equals to p^2 for the first mmf space harmonic $h = 1$ (for higher space harmonics of mmf p is replaced by ph) i.e.

$$\frac{1}{F} \frac{\partial^2 F}{\partial \varphi^2} = -p^2 \quad (14)$$

with the general solution

$$F = C \exp(ip\varphi) + D \exp(-ip\varphi). \quad (15)$$

Eqns (14) and (15) are adequate for rotating magnetic generated by the stator mmf. The angular field frequency ω is determined in comparison to angular speed of mmf space harmonic ($\pm 2\pi f_1/ph$).

The solution (15) for a unidirectional rotating field ($C = 0, D=1$) leads to

$$\frac{\partial^2 R}{\partial r^2} + 2(1 - h(\theta)) \frac{\partial R}{r \partial r} + R \left(-\beta^2 - \frac{p^2 v_{rr} - ip \sin \theta v_{r\varphi}}{r^2 v_{\varphi\varphi} \sin^2 \theta} \right) = 0, \quad (16)$$

with the following analytical solution for an anisotropic region [5] (p. 363 Eqn (B110 (3))):

$$R(r, \theta) = (\beta r)^{h(\theta) - \frac{1}{2}} \left(C_1 I_{\lambda(\theta)}(\beta r) + C_2 K_{\lambda(\theta)}(\beta r) \right) \quad (17)$$

where

$$\lambda(\theta) = \pm \sqrt{(h(\theta) - \frac{1}{2})^2 + \frac{p^2 v_{rr} - ip \sin \theta v_{r\varphi}}{v_{\varphi\varphi} \sin^2 \theta}}, \quad h(\theta) = -\frac{v_{r\varphi} + v_{\varphi r}}{2v_{\varphi\varphi} \sin \theta} ip, \quad \beta^2 = \frac{i\gamma\omega}{v_{\varphi\varphi}}. \quad (18a,b,c)$$

The solution in the form of (17) confirms that the proposed non-standard separation (11) is correct. The Eqn (13) for the non-conductive region (e.g. the air-gap $\gamma=0, v_{r\varphi}=v_{\varphi r}=0$) takes the simpler form of

$$\frac{\partial^2 (rR)}{\partial r^2} - (\kappa(\theta) + 1)\kappa(\theta) \frac{R}{r} = 0, \quad (19)$$

where

$$\kappa(\theta)(\kappa(\theta) + 1) = \frac{v_{r\delta} p^2}{v_{\varphi\delta} \sin^2 \theta}, \quad (20)$$

and $v_{r\delta}, v_{\varphi\delta}$ the mean radial and tangential (latitudinal) reluctivities for the air-gap. The solution of (19) is

$$R = R(r, \theta) = a_{\delta} r^{\kappa_1(\theta)} + b_{\delta} r^{\kappa_2(\theta)}. \quad (21)$$

The analytical solution for the spherical motor can be presented in terms of separated functions $R(r, \theta)$ and $F(\varphi)$ obtained with the help of separation proposed by Eqn (11) - see Table 2. The general solutions presented should be combined with the boundary conditions for particular geometry conditions.

Table 2. Solutions for differential equations for magnetic flux density

Region	anisotropic layer (index a)	gap (index δ)
A = R·F Solutions for R(,) $F = \exp(-ip\varphi)$	$R(r, \theta) = (\beta r)^{h(\theta)-\frac{1}{2}} (C_1 I_{\lambda(\theta)}(\beta r) + C_2 K_{\lambda(\theta)}(\beta r))$ $\lambda(\theta) = \pm \sqrt{(h(\theta) - \frac{1}{2})^2 + \frac{p^2 v_{r\tau} - ip \sin \theta v_{r\varphi}}{v_{\varphi\varphi} \sin^2 \theta}}$ $h(\theta) = -\frac{v_{r\varphi} + v_{\varphi r}}{2v_{\varphi\varphi} \sin \theta} ip$	$R(r, \theta) = a_\delta r^{\kappa_1(\theta)} + b_\delta r^{\kappa_2(\theta)}$ $\kappa(\theta)(\kappa(\theta) + 1) = \frac{v_{r\delta} p^2}{v_{\varphi\delta} \sin^2 \theta}$
Magnetic flux radial components $B_r()$	$B_r = \frac{1}{r \sin \theta} \frac{\partial A}{\partial \varphi} = \frac{-ip}{r \sin \theta} R(r, \theta)$	
Magnetic flux tangential components $B_\varphi()$ $(w = \beta r)$	$B_\varphi = -\frac{1}{r} \frac{\partial (rA)}{\partial r}$	
	$B_\varphi = -\frac{\partial}{r \partial w} \left(w^{h+\frac{1}{2}} (a_a I_\lambda(w) + b_a K_\lambda(w)) \right)$	$B_\varphi = -\frac{1}{r} \left((\kappa_1 + 1) a_\delta r^{\kappa_1} + (\kappa_2 + 1) b_\delta r^{\kappa_2} \right)$
constans	$a_a \quad b_a$	$a_\delta \quad b_\delta$

4. Boundary conditions

There are four conditions defined for the electromagnetic field vectors. They enable to calculate the four unknown constants a_a , b_a , a_δ , b_δ . The boundary conditions result from physical laws [6], [12].

a) The magnetic field strength disappears at the inner layer surface ($r = R-a$)

$$H_\varphi = v_{\varphi r} B_r + v_{\varphi\varphi} B_\varphi = 0, \quad (22)$$

as a consequence of the fact that magnetic relativity of the rotor core is assumed to be zero.

b) The continuity of the normal (radial) magnetic flux density ($r = R$)

$$B_{r\delta} = B_{ra}, \quad (23)$$

and

c) the tangential (longitudinal) component of the magnetic field strength ($r = R$)

$$v_{\varphi\delta} B_{\varphi\delta} = v_{\varphi\varphi} B_{\varphi a} + v_{\varphi r} B_{ra}. \quad (24)$$

d) The magnetomotive force of the electromechanical converter stator currents leads to the following condition for the tangential (longitudinal) component of magnetic field strength at the stator surface ($r = R+g$)

$$B_{\varphi\delta} = \frac{1}{v_{\varphi\delta} r \sin\theta} \frac{\partial \Theta_s}{\partial \varphi}, \quad (25)$$

derived under the assumption that the magnetic field strength vanishes on the outer side of the winding surface (stator frame iron is infinitely permeable) [1], [12], [13]. Table 3 presents constant values of a_a , b_a , a_δ , b_δ for the first space harmonic of the stator mmf.

Table 3. The boundary conditions for magnetic field

Boundary condition	Field excited by stator currents	Constants for solutions (the constants depends on θ , that is not denoted explicit)
Stator current mmf $r = R+g = R_g$	$B_{\varphi\delta} = \frac{1}{v_{\varphi\delta} r \sin\theta} \frac{\partial \Theta_s}{\partial \varphi}$	$a_a = \frac{p_\theta \Theta_s}{v_{\varphi\delta}} \{U(1 + \kappa_1)R_g^{\kappa_1} + W(1 + \kappa_2)R_g^{\kappa_2}\}^{-1}$ $b_a = -a_a S, \quad a_\delta = a_a U, \quad b_\delta = a_a W$
Rotor outer surface $r = R$	$B_{\delta r} = B_{ar},$ $v_{\delta\varphi} B_{\delta\varphi} =$ $= v_{\varphi\varphi} B_{a\varphi} + v_{\varphi r} B_{ar}$	$S = \frac{v_{\varphi\varphi} [nw_a^f I_\lambda(w_a) + w_a^{f+1} I'_\lambda(w_a)] + ip_\theta v_{\varphi r} I_\lambda(w_a) w_a^f}{v_{\varphi\varphi} [nw_a^f K_\lambda(w_a) + w_a^{f+1} K'_\lambda(w_a)] + ip_\theta v_{\varphi r} K_\lambda(w_a) w_a^f},$ $f = h - \frac{1}{2}, \quad n = f + 1, \quad w_a = \beta R_a, \quad w = \beta R,$ $\beta = \sqrt{i\omega\gamma/v_{\varphi\varphi}}, \quad p_\theta = p/\sin(\theta),$
Inner layer surface $r = R-a = R_a$	$v_{\varphi\varphi} B_\varphi + v_{\varphi r} B_r = 0$	$P = \frac{v_{\varphi\varphi}}{v_o} [nw^f I_\lambda(w) + w^n I'_\lambda(w) - S[nw^f K_\lambda(w) + w^n K_\lambda(w)]]$ $+ Q \frac{ip_\theta v_{\varphi r}}{v_{\varphi\delta}}$ $Q = w^f [I_\lambda(w) - SK_\lambda(w)]$ $U = \frac{Q(\kappa_2 + 1) - P}{(\kappa_2 - \kappa_1)R^{\kappa_1}}, \quad W = \frac{P - Q(\kappa_1 + 1)}{(\kappa_2 - \kappa_1)R^{\kappa_2}}$

The electromagnetic field problem can be evaluated analytically with the help of the equations provided in Tables 2 and 3.

5. Example – spherical induction motor

Based on the magnetic field vector potential distribution, both the magnetic flux density components and the electromagnetic torque components can also be evaluated analytically. The Maxwell stress tensor leads to the total electromagnetic torque by means of the well-known formula

$$T_e = \int_0^{2\pi} \int_{\theta_1}^{\theta_2} H_\varphi B_r r^3 \sin^2 \theta d\theta d\varphi, \quad (27a)$$

where r is the radius of the integration surface placed in the air gap $r \in [R, R+g]$. Based on the magnetic field vector components presented in Table 2 for the air-gap region, the electromagnetic torque can be given as follows:

$$T_e = \pi p v_{\varphi \delta} \int_{\theta_1}^{\theta_2} \text{Im} \left\{ r \frac{\partial (r \mathbf{R}(r, \theta))}{\partial r} \mathbf{R}^*(r, \theta) \right\} \sin \theta d\theta. \quad (27b)$$

The total electromagnetic torque can be also evaluated by means of magnetic coenergy as follows

$$T_{eC} = \left. \frac{\partial W_C}{\partial \varphi} \right|_{j=\text{const}} = \int_V (\bar{\mathbf{j}} \frac{\partial \bar{\mathbf{A}}}{\partial \varphi} + \bar{\mathbf{B}} \frac{\partial \bar{\mathbf{H}}}{\partial \varphi}) dV, \quad (28a)$$

where W_C denotes the magnetic coenergy of conducting and magnetically anisotropic rotor. The volume integral for motor rotor takes the form of

$$T_{eC} = \pi \text{Re} \left\{ \int_{\theta_1}^{\theta_2} \int_{R-a}^R (j_z^* \frac{\partial A_z}{\partial \varphi} + B_r \frac{\partial H_r^*}{\partial \varphi} + B_\varphi \frac{\partial H_\varphi^*}{\partial \varphi}) r^2 \sin(\theta) dr d\theta \right\}. \quad (28b)$$

Taking into account the solutions put in Table 2 it can be written

$$\frac{\partial A_z}{\partial \varphi} = \frac{\partial}{\partial \varphi} (R(r, \theta) S(-ip\varphi)) = -ipR(r, \theta) S(-ip\varphi) = -ipA_z, \quad (28c)$$

and analogously for H_r and H_φ , hence it is satisfied

$$T_{eC} = \pi p \text{Im} \left\{ \int_{\theta_1}^{\theta_2} \int_{R-a}^R (j_z^* A_z - B_r H_r^* - B_\varphi H_\varphi^*) r^2 \sin(\theta) dr d\theta \right\}. \quad (28d)$$

Torque evaluated by means of Maxwells and coenergy method are equal each other

$$T_e = T_{eC}. \quad (29)$$

The electromagnetic torque component forced by the rotor currents can be evaluated with the help of the Lorentz force density as

$$T_{eL} = \int_0^{2\pi} \int_{R_a}^R \int_{\theta_1}^{\theta_2} \mathbf{j}_\theta \frac{\partial A_\theta}{\partial \varphi} r^2 \sin \theta d\theta dr d\varphi. \quad (30a)$$

Applying the magnetic field vector components presented in Table 2 for the rotor layer, the Lorentz torque can be rewritten in the form

$$T_{eL} = \pi \gamma p \omega \int_{\theta_1}^{\theta_2} \sin \theta \int_{R_a}^R |\mathbf{R}(r, \theta)|^2 r^2 dr d\theta. \quad (30b)$$

Both torques are equal

$$T_e = T_{eL}, \quad (31)$$

for either magnetically isotropic or normally anisotropic ($v_{\varphi r} = v_{r\varphi}$) rotor.

Exemplary is considered spherical induction motor with mmf harmonics given as follows $\Theta_1 = 559$ A, $\Theta_5 = 50$ A, $\Theta_7 = 0$, $\Theta_{11} = 41$ A, $\Theta_{13} = 43$ A, $\Theta_{17} = 26$ A, and $R = 0.03$ m, $g = 0.0005$ m, $a = 0.01$ m, $\gamma = 30 \cdot 10^6$ S/m (Cu-Fe composite conductor), $p = 2$, $f_1 = 50$ Hz, $\theta_1 = \pi/4$ rad, $\theta_2 = 3\pi/4$ rad for reluctivity matrices given as follows

$$\text{a) } \mathbf{v} = v_0 \begin{bmatrix} 0.7 & 0 \\ 0 & 0.9 \end{bmatrix}, \quad \text{b) } \mathbf{v} = v_0 \begin{bmatrix} 0.8 & 0 \\ 0 & 0.8 \end{bmatrix}, \quad \text{c) } \mathbf{v} = v_0 \begin{bmatrix} 0.9 & 0 \\ 0 & 0.7 \end{bmatrix}.$$

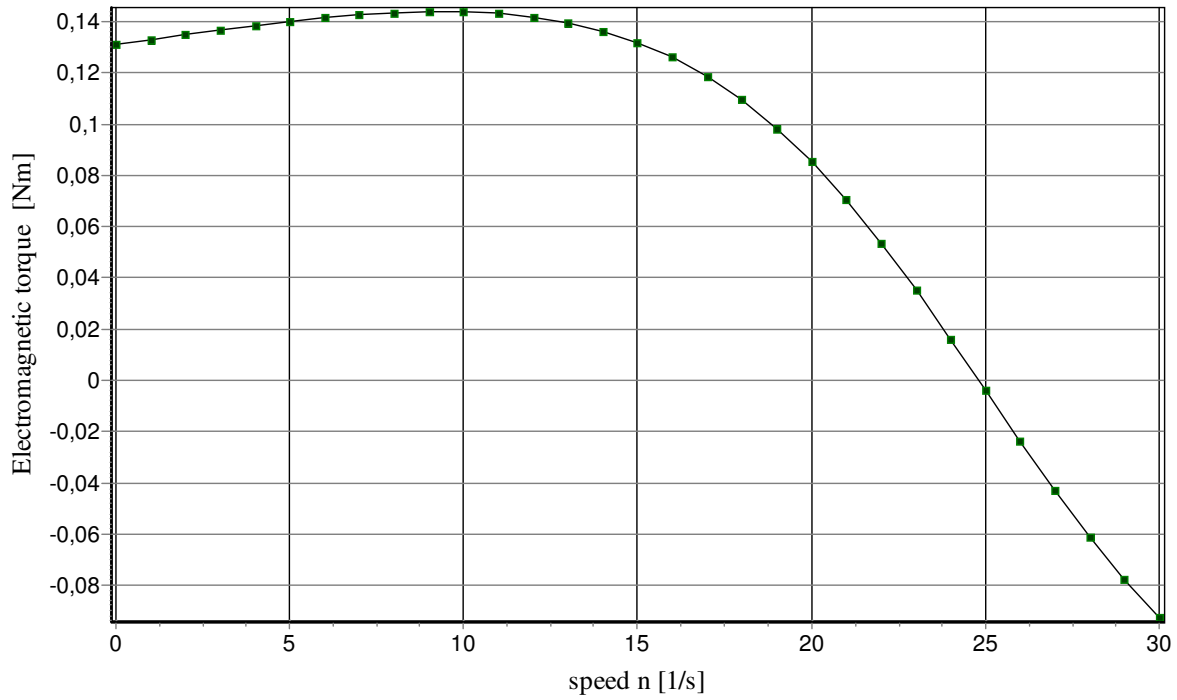

Fig.5. Torque-speed curves for anisotropic rotor $v_r > v_\phi$
Maxwell and coenergy methods (solid line), Lorentza method (dot line)

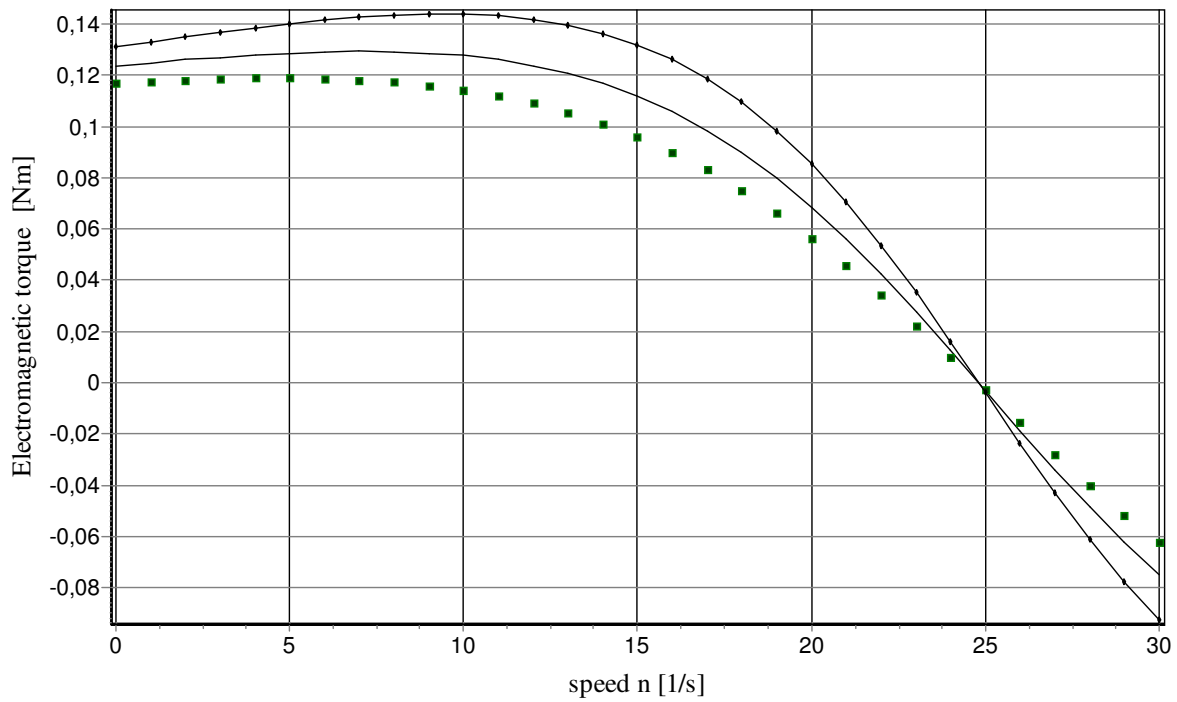

Fig.6. Torque-speed curves for different rotor anisotropy: a) $v_r > v_\phi$ - solid-diamond line,
b) $v_r = v_\phi$ - solid line, c) $v_r > v_\phi$ - dot line (for all cases $v_{r\phi} = v_{\phi r} = 0$)

7. Power losses calculations

The power losses constitute an important parameter from the thermal point of view. Power losses caused by the induced currents are

$$P = \frac{1}{2} \sum_h \int_V \operatorname{Re}\{j_h E_h^*\} dV = \frac{1}{2} \sum_h \gamma \omega_h^2 \int_V |A_h|^2 dV, \quad (32)$$

are shown in Figs. 7 and 8 (h is order number of the h^{th} space harmonic of stator mmf). The power losses can be means of Poynting vector as follows

$$P = -\sum_h \operatorname{Re}\left\{ \int_{S_{\text{out}}} \vec{S}_h d\vec{S}_{\text{out}} \right\}, \quad (33)$$

where \vec{S}_h means h^{th} harmonic of Poynting vector.

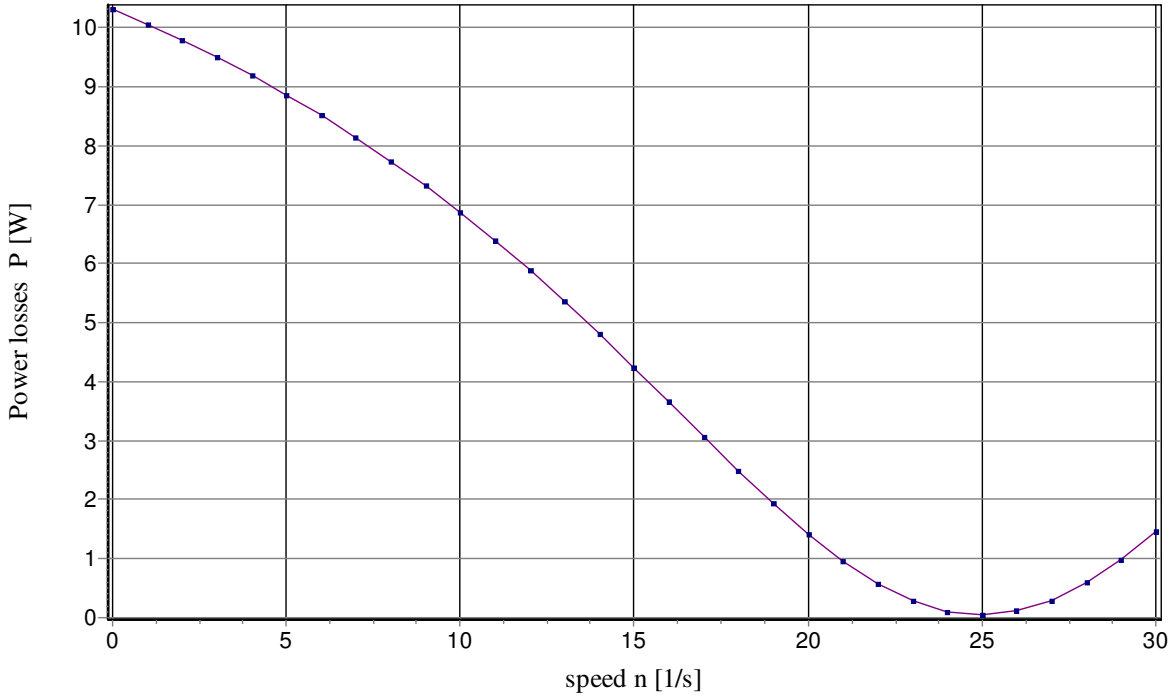

Fig.7. Power losses vs. rotor speed for anisotropic rotor $v_r > v_\phi$
Poynting method (solid line), Joule method (dot line)

8. Conclusions

The Maxwell equations in a spherical co-ordinate system are solved analytically. The mathematical form of the non-standard separation is given by Eqn (11). The analytical solution has been obtained for a magnetically anisotropic and conductive region.

The presented model of an induction motor (with multiharmonic stator magnetomotive force) has been used to calculate the analytical solution for an electromechanical converter in operation.

The electromagnetic torque calculations are provided with the help of the Maxwell and Lorentz methods. For the analytical solutions obtained, the power balance was checked.

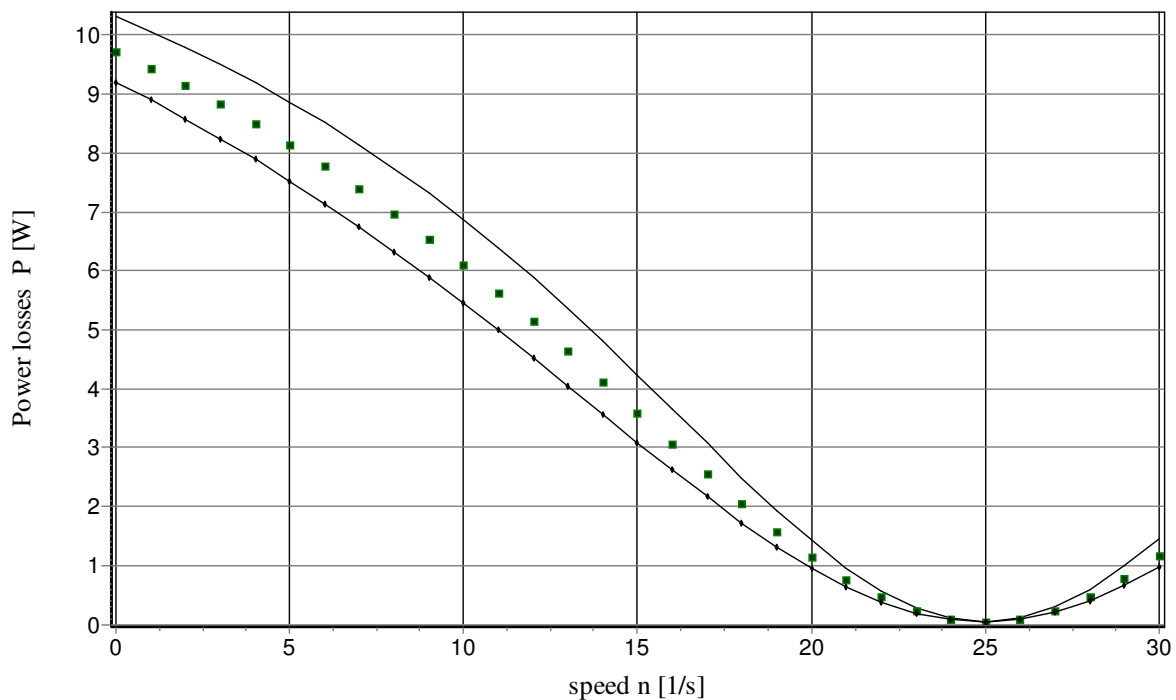

Fig.8. Power losses vs. speed for different rotor anisotropy: a) $v_r > v_\varphi$ - solid-diamond line, b) $v_r = v_\varphi$ - solid line, c) $v_r > v_\varphi$ - dot line (for all cases $v_{r\varphi} = v_{\varphi r} = 0$)

References

- [1] Adkins B., Harley P.G.: The general theory of alternating current machines. Chapman and Hall (1978).
- [2] Davey K., Vachtsevanos G., Powers R.: The analysis of fields and torques in spherical induction motors. IEEE Trans. Magn., Vol. 23, No. 1, pp. 273-282 (1987).
- [3] Demenko A.: Finite element analysis of electromagnetic torque saturation harmonics in a squirrel cage machine. COMPEL, Vol. 18, No. 4, pp. 619-628 (1999).
- [4] Engelmann S., Nethé A., Scholz T., Stahlmann H.-D.: Application of force enhancement with ferrofluids in linear stepping motor model. Proc. ISTET 2003, Warsaw, Poland, Vol. II, pp. 425-428 (2003).
- [5] Gradsztajn I. S., Ryzik I. M.: Tables of integrals, sums, series and derivatives. Moscow 1962 (in Russian).
- [6] Jackson J.: Classical electrodynamics. PWN, Warsaw (1982) (in Polish).
- [7] Joos G.: Lehrbuch der theoretischen Physik. Leipzig (1954) (in German).
- [8] Kamiński G.: Electric motors with rolling rotors. Wyd. Politechnika Warszawska (2003).

- [9] Lee K.-M., Roth R., Zhou Z.: Dynamic modeling and control of a ball-joint-like variable reluctance spherical motor. *ASME J. Dynam. Syst. Meas. Cont.*, Vol. 118, No. 1, pp. 29–40 (1996).
- [10] Nethe A., Scholz T., Stahlmann H-D.: An analytical solution method for magnetic fields using the Fourier analysis and its application of ferrofluid driven electric machines. *Proc. ISTET 2003, Warsaw, Poland, Vol. II*, pp. 421–424 (2003).
- [11] Purczyński J., Kaszycki L.: Power losses and electromagnetic torque of spherical induction motor. *Rozprawy Elektrotechniczne* 34, No. 3, pp. 819–838 (1988) (in Polish).
- [12] Turowski J., Zakrzewski K., Sikora R.: Analysis and synthesis of electromagnetic field. Ossolineum, Warsaw (1990) (in Polish).
- [13] Spalek D.: Fast analytical model of induction motor for approaching rotor eccentricity. *COMPEL*, Vol. 18, No. 4, pp. 570–586 (1999).
- [14] Zhou, Z. Lee, K.-M.: Characterization of a three degrees-of-freedom variable-reluctance spherical motor. *J. Syst. Eng. (special issue on motion control)*, Vol. 4, pp. 60–69 (1994).